

New Linear Ultrasonic Micromotor for Precision Mechatronic Systems

CAD of the Ultrasonic Motor Based on the Piezoceramic Plate

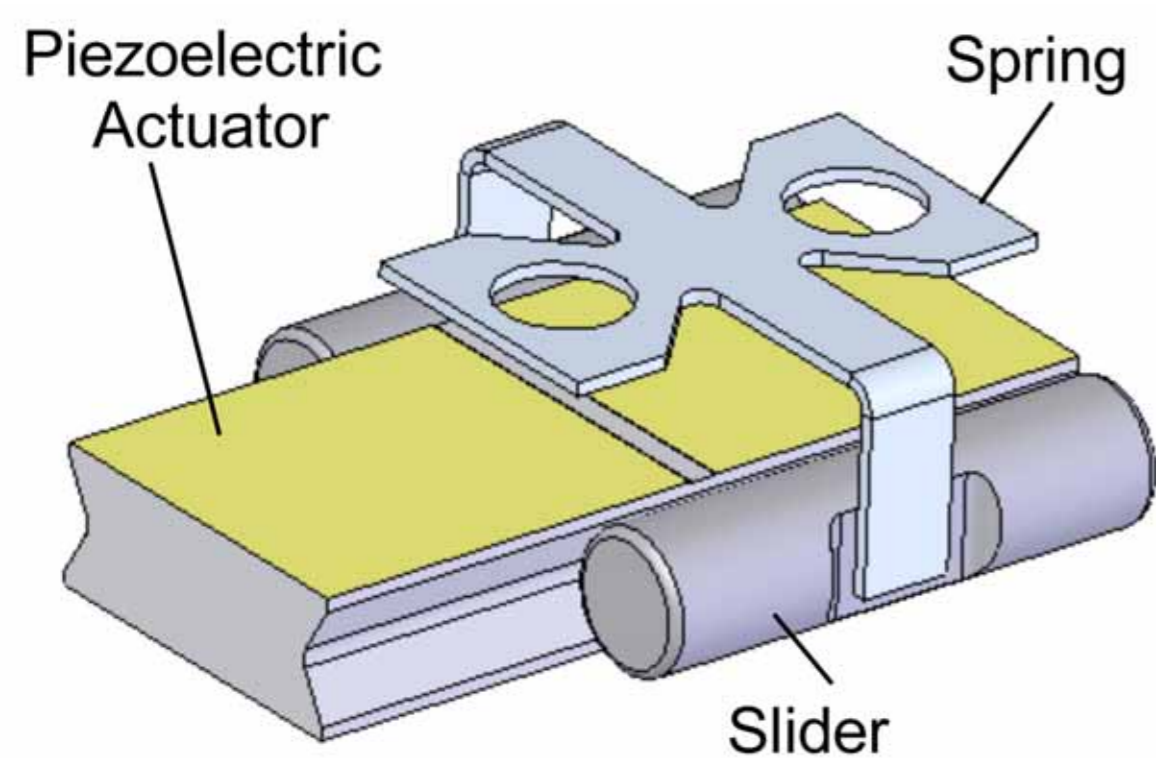

Design Features

- The operating principle of the new ultrasonic motor is based upon asymmetric resonant excitation in the piezoceramic plate in an E(3,1) mode.
- Two sliders, bonded to a spring which presses them against the stator, move along guides integrated in the stator.
- Simple design, consisting of two basic parts: the actuator (stator) and the sled (spring bonded to two sliders), the moving part of the motor
- The simulations, calculations and the optimization of ultrasonic motors were done with the help of ANSYS FEM software.

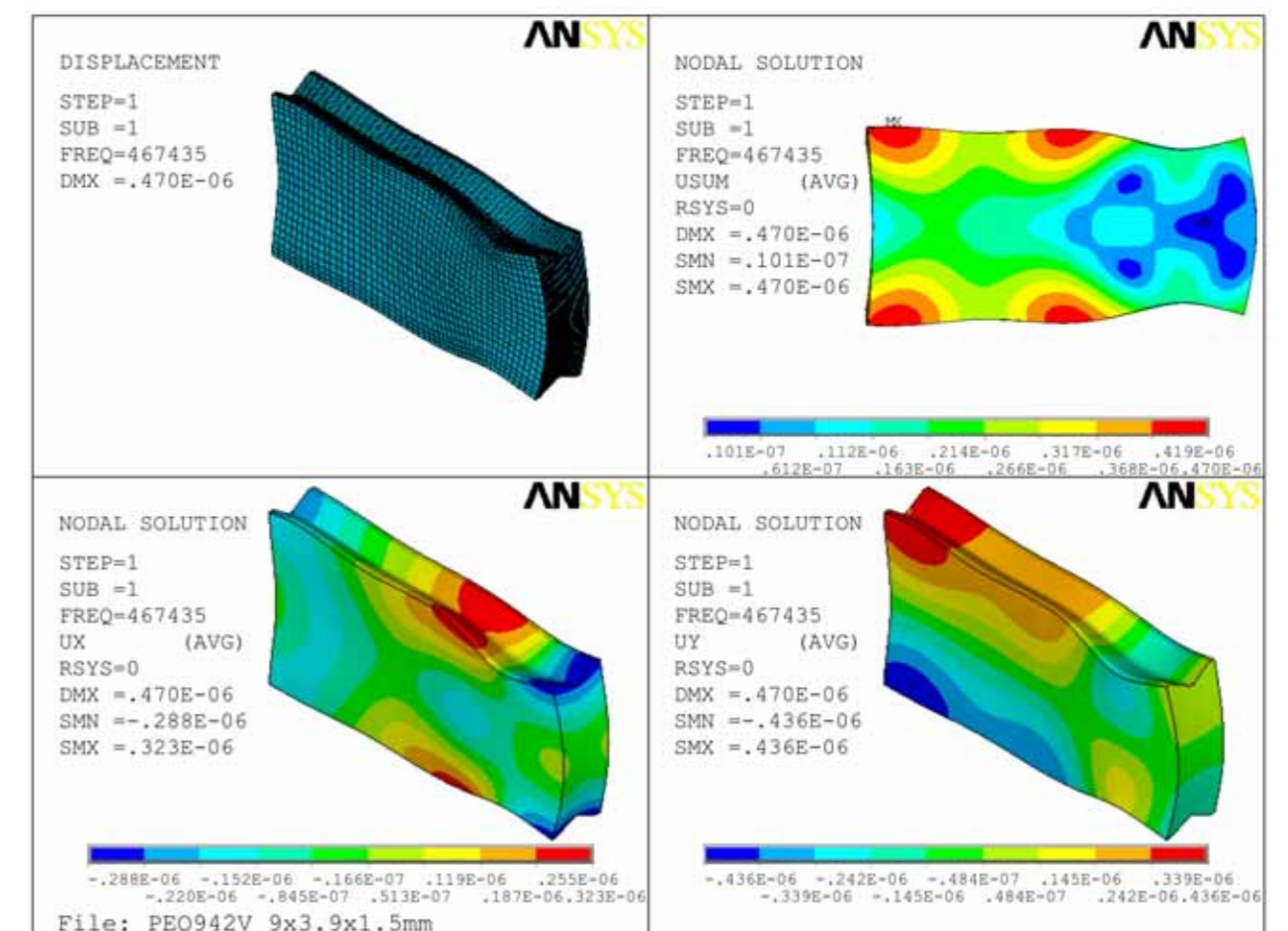

Laser Vibrometer Measurements

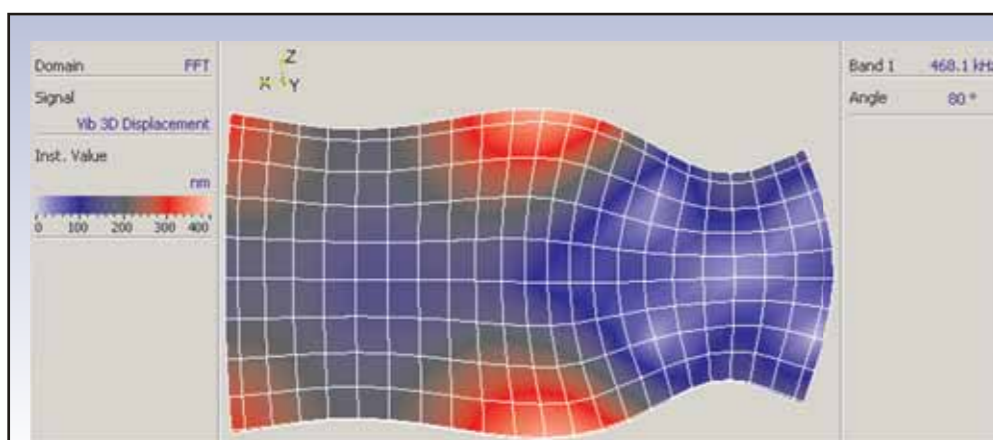

- The vibrational behavior of the actuator was analyzed with a 3D scanning laser vibrometer

Prototypes of the Motors

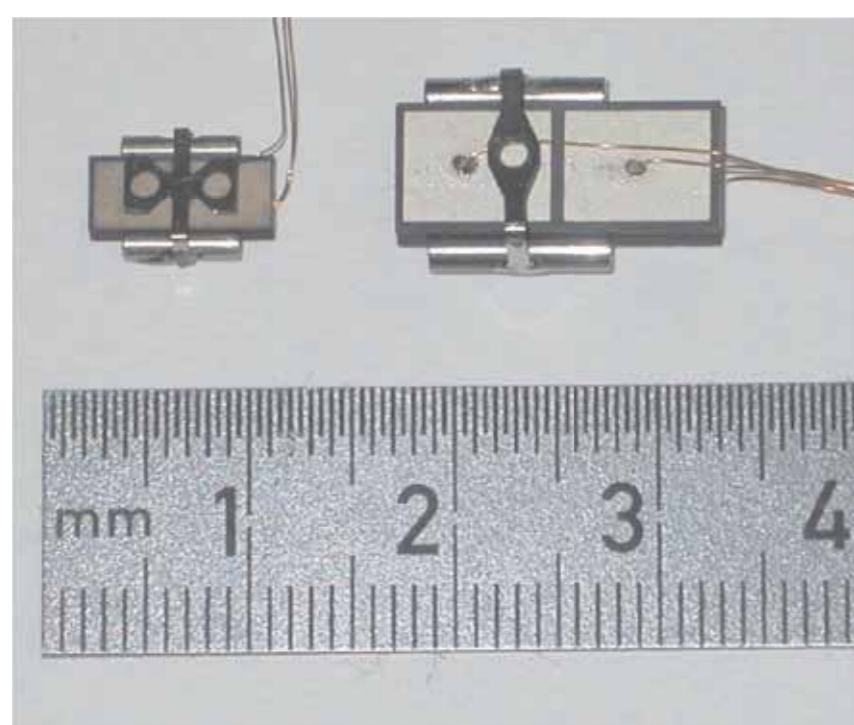

- Two prototypes of the motors using a 9x3.9x1.5 mm³ and a 16x9x1.5 mm³ piezoceramic plate have been designed and tested.

Drive Circuit

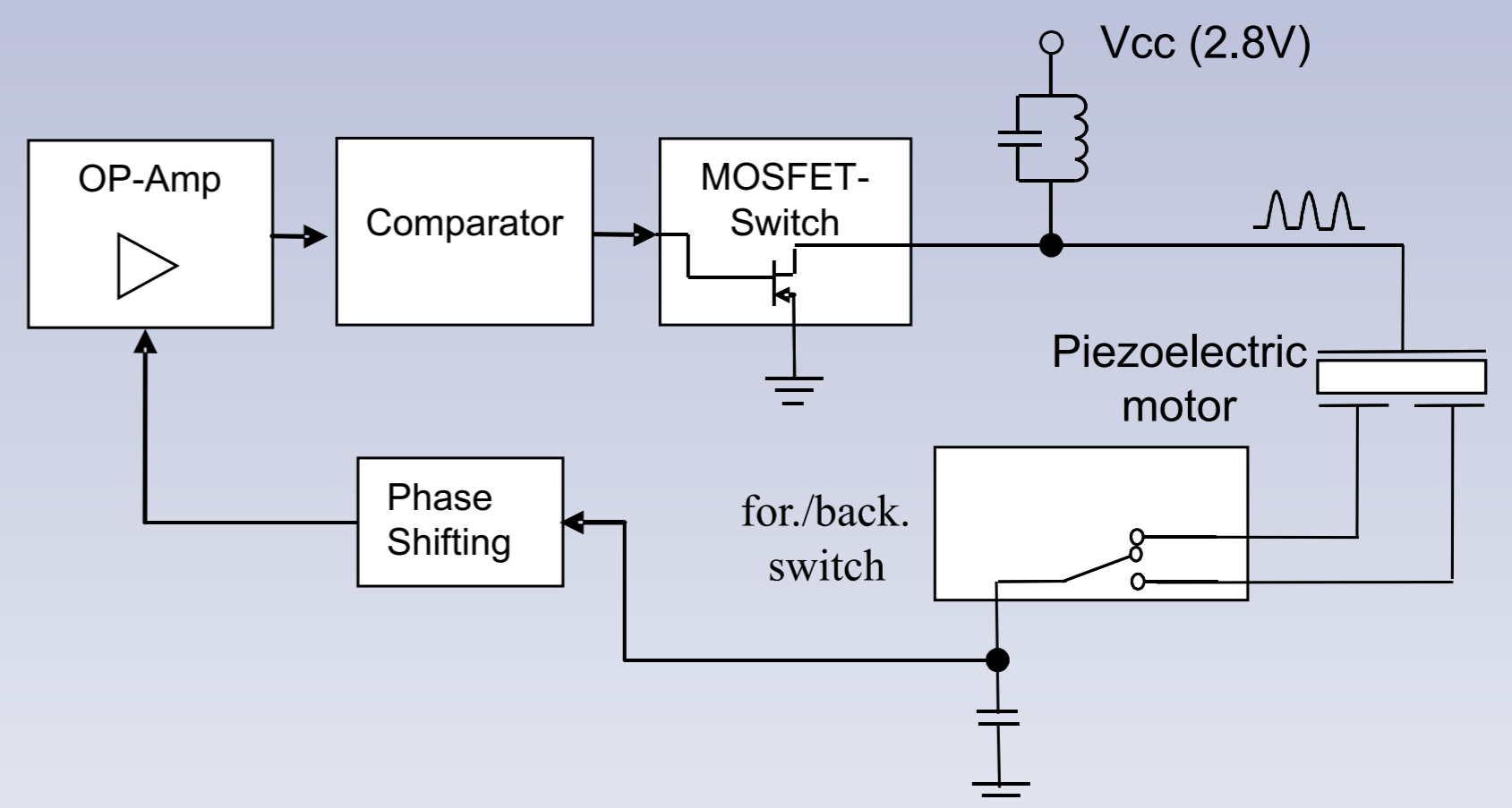

- A simple self-oscillation drive circuit
- With a 3 V supply, it generate an output voltage with an amplitude of 15 V
- Resonant frequency of the 9x3.9x1.5 mm motor is 470kHz
- The drive electronics can easily be implemented in ASIC technology

Conclusions

Advantages

- In open-loop operation, the 9 mm motor attains a speed of up to 100 mm/s.(@ 15Vpp)
- A maximum speed of 180 mm/s can be reached (@25Vpp).
- The smallest possible steps in open-loop mode are 100 nm
- Supply voltage 5-15 Vrms

Drive Characteristics of the 9mm Motor

