

## Piezo Z/Tip/Tilt Platform

### High Dynamics Tripod System for Mirrors and Optics



#### S-325

- Optical beam deflection to 10 mrad
- Resolution to 50 nrad
- Linear travel ranges to 30  $\mu\text{m}$  (for runtime adjustment)
- Compact tripod design
- Sub-ms response time
- Closed-loop versions for increased precision
- For mirrors up to  $\varnothing$  25 mm (1")
- Zero-play, high-precision flexure guide system
- Parallel kinematics for higher accuracy and dynamics

#### Fields of application

- Image processing / stabilization
- Optical trapping
- Laser scanning / beam steering
- Laser tuning
- Optical filters / switches
- Optics
- Beam stabilization

#### Outstanding lifetime thanks to PICMA® piezo actuators

The patented PICMA® piezo actuators are all-ceramic insulated. This protects them against humidity and failure resulting from an increase in leakage current. PICMA® actuators offer an up to ten times longer lifetime than conventional polymer-insulated actuators. 100 billion cycles without a single failure are proven.

#### High guiding accuracy due to zero-play flexure guides

Flexure guides are free of maintenance, friction, and wear, and do not require lubrication. Their stiffness allows high load capacity and they are insensitive to shock and vibration. They are 100 % vacuum compatible and work in a wide temperature range.

#### High dynamics multi-axis operation due to parallel kinematics

In a parallel-kinematic multi-axis system, all actuators act on a common platform. The minimum mass inertia and the identical design of all axes allow fast, dynamic, and nevertheless precision motion.

## Specifications

	S-325.30L	S-325.3SL	S-325.3SD	Unit	Tolerance
Active axes	Z, $\theta_x$ , $\theta_y$	Z, $\theta_x$ , $\theta_y$	Z, $\theta_x$ , $\theta_y$		
<b>Motion and positioning</b>					
Integrated sensor	–	SGS	SGS		
Travel range in Z at 0 to 100 V, open loop	30	30	30	$\mu\text{m}$	+20 % / -0 %
Tip/tilt angle at 0 to 100 V, open loop	5	5	5	mrad	+20 % / -0 %
Travel range in Z, closed loop	–	30	30	$\mu\text{m}$	
Tip / tilt angle in $\theta_x$ , $\theta_y$ , closed loop	–	4	4	mrad	
Resolution in Z, open loop	0.5	0.5	0.5	nm	typ.
Resolution in $\theta_x$ , $\theta_y$ , open loop	0.05	0.05	0.05	$\mu\text{rad}$	typ.
Resolution in Z, closed loop	–	0.6	0.6	nm	typ.
Closed-loop resolution in $\theta_x$ , $\theta_y$	–	0.1	0.1	$\mu\text{rad}$	typ.
<b>Mechanical properties</b>					
Resonant frequency in Z, no load	2	2	2	kHz	$\pm 20\%$
Resonant frequency, under load (with 25 mm $\times$ 8 mm glass mirror)	1	1	1	kHz	$\pm 20\%$
Distance of pivot point to platform surface	6	6	6	mm	$\pm 0.5\text{ mm}$
Platform moment of inertia	515	515	515	$\text{g} \times \text{mm}^2$	$\pm 20\%$
<b>Drive properties</b>					
Ceramic type	PICMA® P-885	PICMA® P-885	PICMA® P-885		
Electrical capacitance	3 $\times$ 3.1	3 $\times$ 3.1	3 $\times$ 3.1	$\mu\text{F}$	$\pm 20\%$
<b>Miscellaneous</b>					
Operating temperature range	-20 to 80	-20 to 80	-20 to 80	$^{\circ}\text{C}$	
Housing material	Aluminum	Aluminum	Aluminum		
Mass	0.065	0.065	0.065	kg	$\pm 5\%$
Cable length	2	2	2	m	+100 mm / -0 mm
Sensor / voltage connection	LEMO	LEMO	D-sub 25 (m)		
Recommended electronics	E-610, E-616, E-663, E-727	E-610, E-616, E-663, E-727	E-610, E-616, E-663, E-727		

The resolution of the system is limited only by the noise of the amplifier and the measuring technology because PI piezo nanopositioning systems are free of friction.

For maximum tilt range, all three piezo actuators must be biased at 50 V. Due to the parallel-kinematics design, linear travel and tip/tilt angle are interdependent. The specified values are the maximum for pure linear respectively tilt motion.

All specifications based on room temperature (22  $^{\circ}\text{C} \pm 3\text{ }^{\circ}\text{C}$ ).

## Drawings / Images

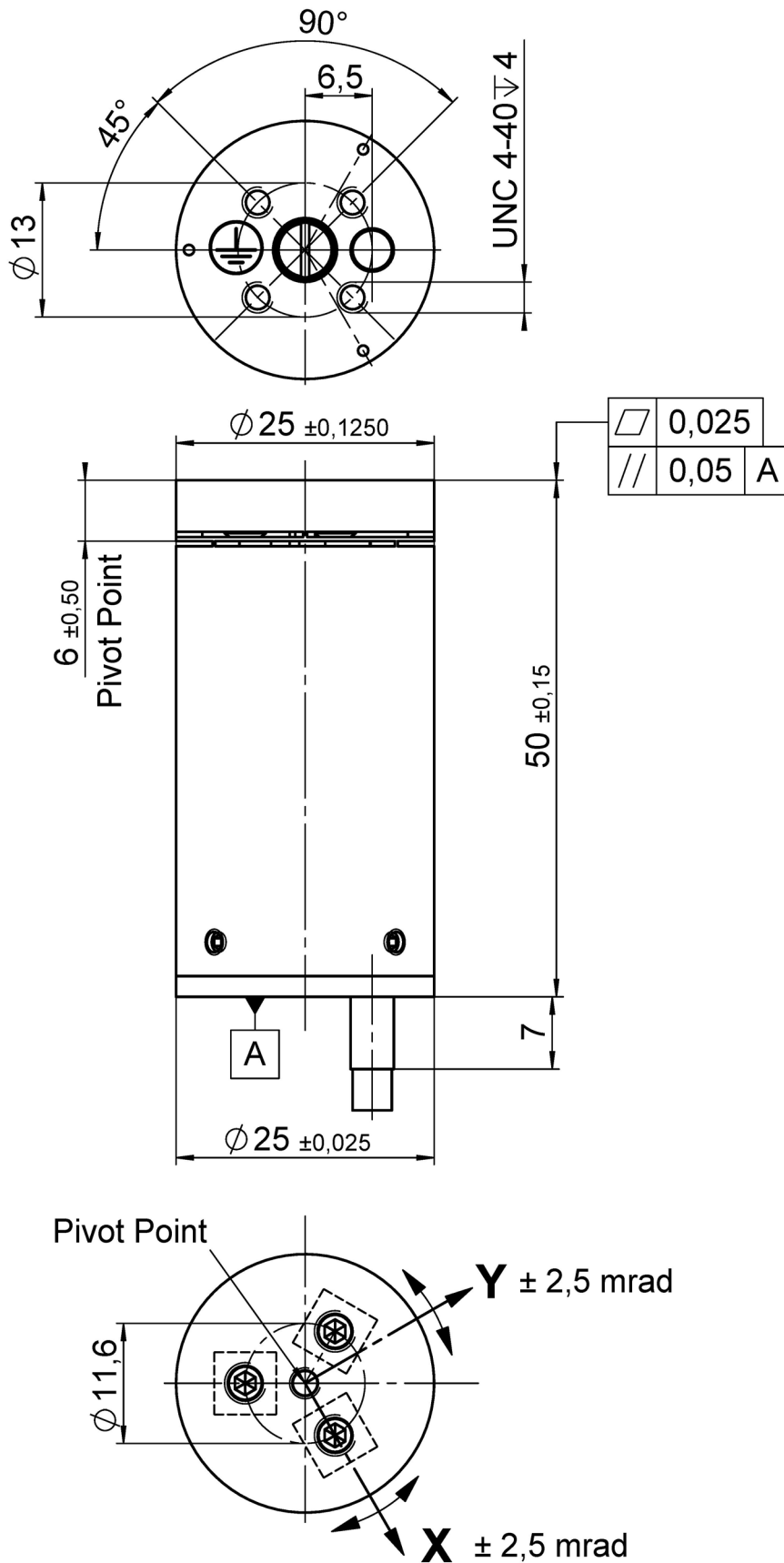

S-325, dimensions in mm

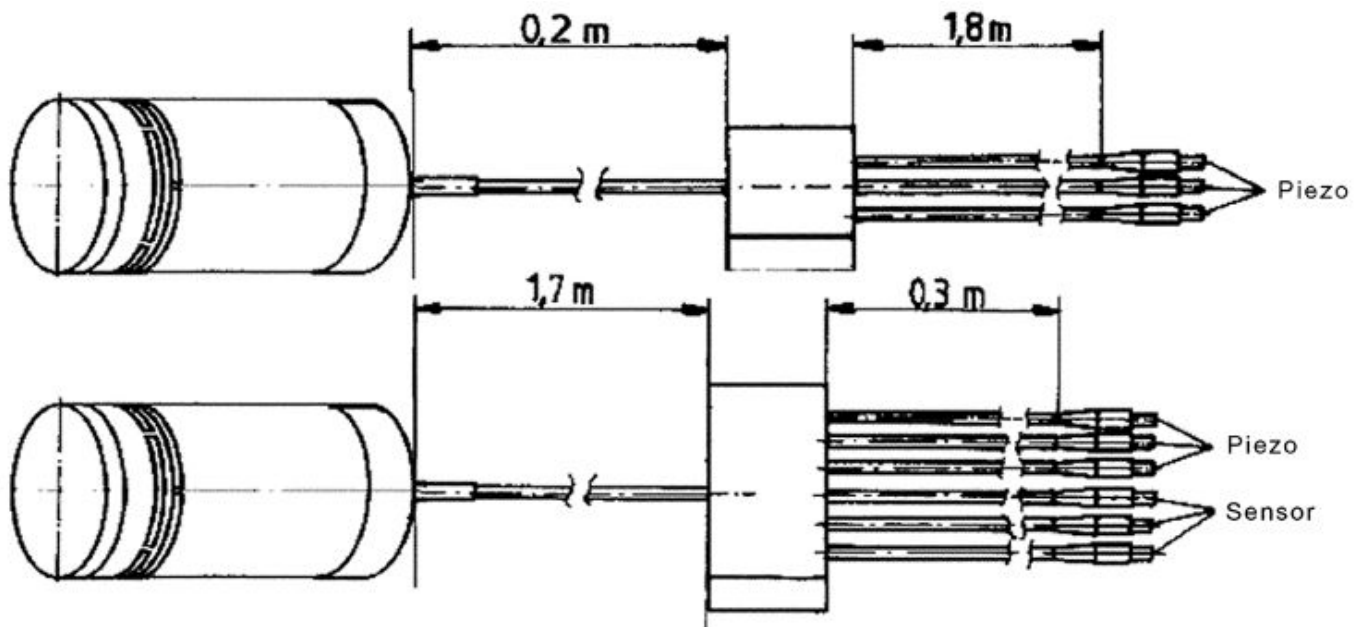

*S-325, cable configuration (S-325.30L: Above; S-325.3SL: Below)*

## Ordering Information

### **S-325.3SD**

High dynamics 3-axis piezo tip/tilt system, 5 mrad, 30  $\mu\text{m}$ , strain gauge sensors, D-sub connector

### **S-325.3SL**

High dynamics 3-axis piezo tip/tilt system, 5 mrad, 30  $\mu\text{m}$ , strain gauge sensors, LEMO connectors

### **S-325.30L**

High dynamics 3-axis piezo tip/tilt system, 5 mrad, 30  $\mu\text{m}$ , without sensors, LEMO connectors