

N-661 Miniature Linear Slide with NEXACT® Drive

PiezoWalk® Drive Provides Nanometer Precision, Smooth Motion and Rapid Response



The N-661 miniature linear stage integrates a PiezoWalk® NEXACT® linear motor combined with a high-resolution linear encoder. It provides 20 mm travel and resolution down to the nanometer range.

- **Travel Range 20 mm**
- **Self Locking at Rest, no Heat Generation, no Servo Dither**
- **Compact Design: 70 x 50 x 20 mm**
- **Zero-Wear Piezo Stepping Drive, Ideal for Micro- and Nano-Manipulation**
- **Integrated Linear Encoder Option for Highest Accuracy with 20 nm Resolution**
- **Two Operating Modes: Continuous Stepping Mode and Continuously Variable, High-Dynamics Analog Mode for 30 μ m Resolution**
- **Up to 10 N Force Generation**

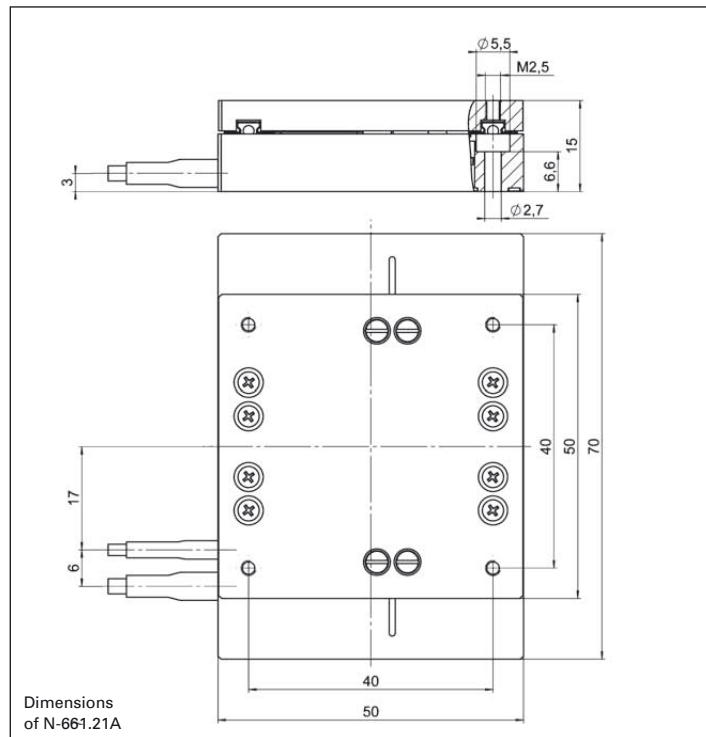

The compact N-661 nanopositioning stage is based on the NEXACT® PiezoWalk® drive. This dual-mode, high-performance piezo stepping linear motor can provide sub-nanometer resolution and high force, along with very rapid response. When run in its analog mode, fast oscillations with amplitudes up to 7 microns and resolutions down to 30 μ m can be achieved. This mode is of great value in high-throughput applications as well as in dynamic laser tuning, cell penetration applications, or even for active vibration damping. The stage is equipped with a precision guiding system and an optical linear encoder to enable highly repeatable positioning.

Ordering Information

N-661.21A
Miniature NEXACT® Translation Stage, 20 mm, Linear Encoder, 20 nm Resolution

Ask about custom designs

Application Examples

- Life science
- Photonics
- Laser tuning
- Motion in strong magnetic fields

The products described in this document are in part protected by the following patents:
German Patent No. P4408618.0

Technical Data

Model	N-661.21A
Active axes	X
Motion and positioning	
Travel range	20 mm
Step size in stepping mode (open-loop)	To 5 μ m
Integrated sensor	Linear encoder
Sensor resolution	20 nm *
Travel range in analog mode	7 μ m
Open-loop resolution	0.03 nm
Closed-loop resolution	20 nm*
Bidirectional repeatability	200 nm
Pitch	500 μ rad
Yaw	150 μ rad
Max. Step frequency (open-loop)	0.8 kHz
Max. velocity	10 mm/s*
Mechanical properties	
Stiffness in motion direction	2.4 N/ μ m
Max. load capacity	20 N
Max. push / pull force (active)	10 N
Max. holding force (passive)	15 N
Lateral Force	20 N
Drive properties	
Drive type	NEXACT® linear drive
Operating Voltage	-10 V to +45 V
Miscellaneous	
Operating temperature range	0 to 50 °C
Material	Aluminum
Mass	150 g
Cable length	1.5 m
Connector	15-pin sub-HDD connector, one channel
Recommended controller/driver	E-861.1A1 Controller for NEXACT® (see p. 1-20)

*With E-861. Depending on drive electronics.