

E-852 PISeca™ Signal Conditioner

For Capacitive Single-Plate Sensors



E-852 signal conditioner electronics with PISeca™ capacitive sensor probes D-510.100, D-510.050, D-510.020 (from left)

- **Cost-Effective System Solution for PISeca™ Capacitive Position Sensors**
- **Integrated Linearization System (ILS) for Maximum Linearity**
- **Selectable Bandwidth from 10 Hz up to 10 kHz**
- **Selectable Measurement Range**
- **LED-Bar Measuring-Range Display for Easy Integration**
- **External Synchronization for Multi-Channel Applications**

The E-852 analog sensor electronics is specially designed for the PISeca™ single-electrode capacitive position sensor. It features minimum noise and exceptional long-term stability. The combination of PISeca™ electronics and D-510 series sensors (s.p. 3-8) provides a system for capacitive displacement measurement with flexible high-end solutions for best linearity and highest resolution. Two versions are available: The E-852.10 offers a standard sensor cable length of 1 m. E-852.10A1 features an external

signal amplifier to allow longer distances between sensor and signal conditioner up to 10 m. Delivery includes all required cables and accessories.

Easy Sensor Installation

The integration of the sensor is facilitated by adjustment aids: the position can be monitored by means of the LED-bar of the E-852.10 or by the extra test point on the signal amplifier of the E-852.10A1.

Capacitive Position Sensors for Highest Accuracy

Single-electrode capacitive (capacitance) sensors are direct metrology devices. They use an electric field to measure change of capacitance between the probe and a conductive target surface, without physical contact. This makes them free of friction and hysteresis and provides high phase fidelity and bandwidth.

Selectable Bandwidth and Measurement Range

The selectable bandwidth setting allows the user to adapt the system to different applications. For the highest accuracy and sub-nanometer resolution, the bandwidth can be limited to 10 Hz.

For high-dynamics applications, the bandwidth can be increased up to 10 kHz while the resolution still remains in the 1 nm range.

The operator can choose a measurement range from 20 to 500 μm , depending on the nominal measurement range of the selected sensor.

Factory Calibration for Improved Linearity

Highest possible linearity and accuracy are achieved with factory calibration of the sensor probe together with the signal conditioner electronics. Two measurement ranges can be calibrated at the same time for one particular sensor probe. Factory calibration also optimizes parameters like ILS (linearization), gain and offset and eliminates cable capacitance influences.

Ordering Information

E-852.10
PISeca™ Signal Conditioner Electronics for Single Electrode Capacitive Sensors, 1 Channel, Low-Noise Power Supply Included

E-852.10A1
PISeca™ Signal Conditioner Electronics for Single Electrode Capacitive Sensors, 1 Channel, Low-Noise Power Supply & External Preamp for 10 m Cables Included

Ask about custom designs!

Integrated Linearization System (ILS) for Highest Accuracy

A proprietary linearization circuit compensates the influences of parallelism errors between sensor and target and guarantees an excellent measuring linearity (to 0.1%).

External Synchronization for Multi-Axis Applications

PISeca™ sensor electronics are equipped with I/O lines for the synchronization of multiple sensor systems.



E-852.10A1 allows longer distances up to 10 m between sensor signal amplifier and signal conditioner. Other cable lengths on request

Application Examples

- Semiconductor technology/ test & measurement
- Data storage
- Automotive industry
- Metrology
- Precision machining

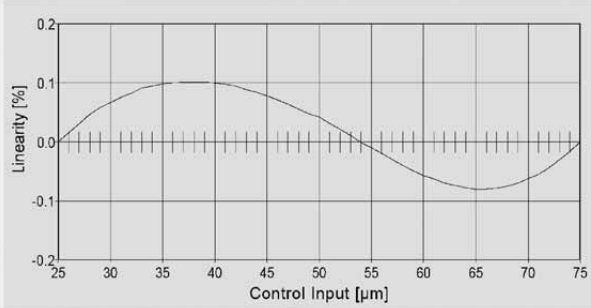

Excellent output linearity of the E-852 signal conditioner / D-510.050 sensor combination (nominal measurement range)

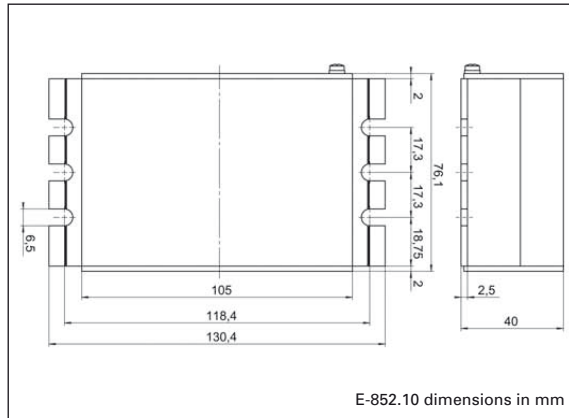

E-852.10 dimensions in mm

Linear Actuators & Motors

Nanopositioning / Piezoelectrics

Nanometrology

Capacitive Sensors /
Signal Conditioners

Nanometrology Fundamentals

Micropositioning

Index

Technical Data

Model	E-852	E-852.10A1	Units
Function	Signal conditioner for PISeca™ capacitive sensor probes	Signal conditioner for PISeca™ capacitive sensor probes, remote operation	
Channels	1	1	
Sensor			
Sensor type	Single-electrode, capacitive	Single-electrode, capacitive	
Sensor bandwidth	10 / 3 / 0.3, 1.1 / 0.1 / 0.01 (option)	10 / 3 / 1 / 0.3 / 0.01	kHz
Measurement range extension factors*	1 & 2.5 (calibrated); 2 & 5 (optional)	1 (calibrated) / 2 / 2.5 / 5 (on request)	
Ext. synchronization	Auto master-slave	Auto master-slave	
Temperature stability	0.71 ±0.25	0.2	mV / K
Electrical properties			
Output voltage	-10 to +10 / -5 to +5 / 0 to +10 V (selectable)	-10 to +10 / -5 to +5 / 0 to +10 (selectable)	V
Output signal	1 kΩ / 1 nF	1 kΩ / 1 nF	
Supply voltage	±15 V (125 mA), +5 V (20 mA)	±15 V (220 mA), +5 V (20 mA)	V
Static resolution**	<0.001% of measurement range (RMS)	<0.001% of measurement range (RMS)	
Dynamic resolution**	<0.002% of measurement range (RMS)	<0.002% of measurement range (RMS)	
Noise factor***	0.14	0.14	ppm/√Hz
Linearity @ nominal range	<0.1 (<0.2% for D-510.020)	<0.1 (<0.2% for D-510.020)	%
Interfaces and operation			
Sensor connection	LEMO ECP.00.650.NLL.543 socket, triaxial	LEMO ECP.00.650.NLL.543 socket, triaxial (on signal amplifier) Sub-D 9-pin, 10 m cable from signal amplifier to signal conditioner, differential signals	
Signal output	BNC	BNC	
Signal monitor	–	Test point on signal amplifier	
Display	LED bar	LED Power On	
Linearization	ILS (Integrated Linearization System)	ILS (Integrated Linearization System)	
Miscellaneous			
Operating temperature range	+5 to +40	+5 to +40	°C
Mass	Signal conditioner: 0.355 Power supply E-852.PS2: 0.55	Signal conditioner: 0.355 Power supply E-852.PS2: 0.55 Signal amplifier: 0.076	kg
Dimensions	Signal conditioner: 80x130x40 Power supply E-852.PS2: 146x76x43 (incl. mounting flanges)	Signal conditioner: 80x130x40 Power supply E-852.PS2: 146x76x43 Signal amplifier: 55x70x20 (incl. mounting flanges)	mm
Target ground connector	Banana jack, 4 mm	Banana jack, 4 mm, on signal amplifier	

*Extension factors to multiply by the nominal measurement range of D-510 sensor probes

**Static: bandwidth 10 Hz, dynamic: bandwidth 10 kHz, cable length 1 m

***Specifications in ppm (parts per million), refer to nominal measurement range