

Hexapod Motion Controller with EtherCAT

Control a 6-Axis Positioning System via Fieldbus Interface



C-887.53x

- Integration into an automation system
- Synchronous motion in 6 axes
- Cycle time ≥ 1 ms
- Commanding in Cartesian coordinates
- High-resolution analog inputs and motion stop as an option

Digital controller with EtherCAT fieldbus interface

Digital controller for hexapods (6-axis parallel kinematics). In addition, the motor drivers for two further single axes can be controlled. For operation in an EtherCAT network, a higher-level programmable logic controller (PLC) is required on the user side (EtherCAT master with CoE protocol). Operation without PLC is possible via TCP/IP or RS-232. The controller then corresponds to a C-887.52x in terms of functionality and is controlled with the GCS 2.0 command set.

Functions

The position is entered in Cartesian coordinates from which the controller calculates the control of the kinematics. To simplify integration of the hexapod, the coordinate systems (Work, Tool) can be changed. The pivot point can be freely defined. A data recorder can record operating data, e.g., motor control, velocity, position, or position error. The execution of macros and Python scripts on the controller enables stand-alone operation. The controller supports all currently available standard hexapods from PI and, in addition, customer-specific parallel kinematics.

Interfaces

EtherCAT fieldbus interface. TCP/IP for network-based control and maintenance. RS-232. USB port for manual control unit.

Additional interfaces (depending on version):

- High-resolution and extremely fast analog inputs which are ideal for fast alignment routines
- Connection for a motion stop button that activates/deactivates the 24 V output for the hexapod

Optional

- Control via manual control unit

Software support (for control via GCS)

For example, PIMikroMove user software enables fast alignment routines to be depicted graphically. Extensive set of drivers, e.g., for use with C, C++, C#, NI LabVIEW, MATLAB, and Python. PIHexapodEmulator for virtual startup and operation without hardware.

Scope of delivery

The scope of delivery includes the controller, a software package, and a power adapter for the power supply. It is recommended to order the hexapod mechanics and a suitable cable set together with the controller so that the components can be adapted to each other. A PLC master controller is not included in the scope of delivery!

Basics	Unit	C-887.53	C-887.531	C-887.532	C-887.533
Axes/channels		6	6	6	6
Additional axes		2 single axes	2 single axes	2 single axes	2 single axes
Processor		Intel Atom dual core (1.8 GHz)	Intel Atom dual core (1.8 GHz)	Intel Atom dual core (1.8 GHz)	Intel Atom dual core (1.8 GHz)
Application-related functions		Controller macros GCS Controller macros PIPython Data recorder Startup macro	Controller macros GCS Controller macros PIPython Data recorder Fast alignment Startup macro	Controller macros GCS Controller macros PIPython Data recorder Startup macro	Controller macros GCS Controller macros PIPython Data recorder Fast alignment Startup macro
Protective functions		Switch-off of the servo mode in case of an error	Switch-off of the servo mode in case of an error	Switch-off via an external switch Switch-off of the servo mode in case of an error	Switch-off via an external switch Switch-off of the servo mode in case of an error
Configuration management		reading the ID chip manual parameter input	reading the ID chip manual parameter input	reading the ID chip manual parameter input	reading the ID chip manual parameter input
Supported ID chip		ID chip 2.0	ID chip 2.0	ID chip 2.0	ID chip 2.0

Motion and Control	Unit	C-887.53	C-887.531	C-887.532	C-887.533
Supported sensor signal		A/B quadrature, RS-422 BiSS-C	A/B quadrature, RS-422 BiSS-C	A/B quadrature, RS-422 BiSS-C	A/B quadrature, RS-422 BiSS-C
Closed-loop values		Position	Position	Position	Position
Maximum control frequency (servo cycle)	Hz	10000	10000	10000	10000
Motion types		Point-to-point motion with profile generator Cyclic transfer of target positions Area scan routines Gradient search routines Wave generator	Point-to-point motion with profile generator Cyclic transfer of target positions Area scan routines Gradient search routines Wave generator	Point-to-point motion with profile generator Cyclic transfer of target positions Area scan routines Gradient search routines Wave generator	Point-to-point motion with profile generator Cyclic transfer of target positions Area scan routines Gradient search routines Wave generator
Motion coordination		Coordinated multi-axis motion User-defined coordinate systems Work-and-tool coordinate systems	Coordinated multi-axis motion User-defined coordinate systems Work-and-tool coordinate systems	Coordinated multi-axis motion User-defined coordinate systems Work-and-tool coordinate systems	Coordinated multi-axis motion User-defined coordinate systems Work-and-tool coordinate systems
Reference switch input		TTL	TTL	TTL	TTL
Limit switch input		TTL	TTL	TTL	TTL

Interfaces and Operation	Unit	C-887.53	C-887.531	C-887.532	C-887.533
Communication interfaces		EtherCAT slave RS-232 TCP/IP USB (only for manual control units)	EtherCAT slave RS-232 TCP/IP USB (only for manual control units)	EtherCAT slave RS-232 TCP/IP USB (only for manual control units)	EtherCAT slave RS-232 TCP/IP USB (only for manual control units)
On/off switch		Hardware switch on/off	Hardware switch on/off	Hardware switch on/off	Hardware switch on/off
Display and indicators		Status LED Error LED Power LED Macro LED	Status LED Error LED Power LED Macro LED	Status LED Error LED Power LED Macro LED	Status LED Error LED Power LED Macro LED
Manual control(s)		Manual control unit with USB interface	Manual control unit with USB interface	Manual control unit with USB interface	Manual control unit with USB interface
Command set		GCS 2.0	GCS 2.0	GCS 2.0	GCS 2.0
User software		PIMikroMove	PIMikroMove	PIMikroMove	PIMikroMove
Software - APIs		C, C++, C# MATLAB NI LabView Python	C, C++, C# MATLAB NI LabView Python	C, C++, C# MATLAB NI LabView Python	C, C++, C# MATLAB NI LabView Python
Analog inputs		4	6	4	6
Analog input signal		4 x -10 to 10 V, 12 bit	2 x -5 to 5 V, 16 bit, 5 kHz bandwidth 4 x -10 to 10 V, 12 bit	4 x -10 to 10 V, 12 bit	2 x -5 to 5 V, 16 bit, 5 kHz bandwidth 4 x -10 to 10 V, 12 bit
Digital inputs		4	4	4	4
Digital input signal		TTL	TTL	TTL	TTL
Digital outputs		4	4	4	4
Digital output signal		TTL	TTL	TTL	TTL
Industrial Ethernet protocol		EtherCAT	EtherCAT	EtherCAT	EtherCAT
EtherCAT device class		EtherCAT slave	EtherCAT slave	EtherCAT slave	EtherCAT slave
EtherCAT communication profile		CAN application protocol over EtherCAT (CoE)	CAN application protocol over EtherCAT (CoE)	CAN application protocol over EtherCAT (CoE)	CAN application protocol over EtherCAT (CoE)
Drive profile implemented for EtherCAT		CiA402 drive profile (IEC 61800-7-201)	CiA402 drive profile (IEC 61800-7-201)	CiA402 drive profile (IEC 61800-7-201)	CiA402 drive profile (IEC 61800-7-201)
Supported operating modes according to CiA402		Homing mode Cyclic synchronous position mode (CSP) Safe basic state for activating coordinate systems (no mode changes / no mode selected)	Homing mode Cyclic synchronous position mode (CSP) Safe basic state for activating coordinate systems (no mode changes / no mode selected)	Homing mode Cyclic synchronous position mode (CSP) Safe basic state for activating coordinate systems (no mode changes / no mode selected)	Homing mode Cyclic synchronous position mode (CSP) Safe basic state for activating coordinate systems (no mode changes / no mode selected)
EtherCAT cycle time		≥1 ms	≥1 ms	≥1 ms	≥1 ms
EtherCAT synchronization modes		Distributed clocks (DC) Synchronous with SYNC0 event	Distributed clocks (DC) Synchronous with SYNC0 event	Distributed clocks (DC) Synchronous with SYNC0 event	Distributed clocks (DC) Synchronous with SYNC0 event

Electrical Properties	Unit	C-887.53	C-887.531	C-887.532	C-887.533
Output voltage	V	24	24	24	24
Peak output current	mA	6000	6000	6000	6000

Miscellaneous	Unit	C-887.53	C-887.531	C-887.532	C-887.533
Connector hexapod power supply		M12 4-pole (f)	M12 4-pole (f)	M12 4-pole (f)	M12 4-pole (f)
Connector hexapod data transmission		HD D-sub 78 (f)	HD D-sub 78 (f)	HD D-sub 78 (f)	HD D-sub 78 (f)
Connector additional axes		D-sub 15 (f)	D-sub 15 (f)	D-sub 15 (f)	D-sub 15 (f)
Connector analog input		HD D-sub 26 (f)	BNC HD D-sub 26 (f)	HD D-sub 26 (f)	BNC HD D-sub 26 (f)
Connector digital input		HD D-sub 26 (f)	HD D-sub 26 (f)	HD D-sub 26 (f)	HD D-sub 26 (f)
Connector digital output		HD D-sub 26 (f)	HD D-sub 26 (f)	HD D-sub 26 (f)	HD D-sub 26 (f)
Connector motion stop button		—	—	M12 8-pole (f)	M12 8-pole (f)
Connector TCP/IP		RJ45 socket, 8P8C	RJ45 socket, 8P8C	RJ45 socket, 8P8C	RJ45 socket, 8P8C
Connector RS-232		D-sub 9 (m)	D-sub 9 (m)	D-sub 9 (m)	D-sub 9 (m)
Connector EtherCAT		RJ45 socket, 8P8C	RJ45 socket, 8P8C	RJ45 socket, 8P8C	RJ45 socket, 8P8C
Connector for supply voltage		M12 4-pole (m)	M12 4-pole (m)	M12 4-pole (m)	M12 4-pole (m)
Operating voltage	V	24 (ext. power adapter included)	24 (ext. power adapter included)	24 (ext. power adapter included)	24 (ext. power adapter included)
Power adapter		Included in the scope of delivery Power adapter 24 V DC	Included in the scope of delivery Power adapter 24 V DC	Included in the scope of delivery Power adapter 24 V DC	Included in the scope of delivery Power adapter 24 V DC
Maximum current consumption	A	8	8	8	8
Operating temperature range	°C	5 to 40	5 to 40	5 to 40	5 to 40
Overall mass	g	2800	2800	2800	2800

Drawings / Images

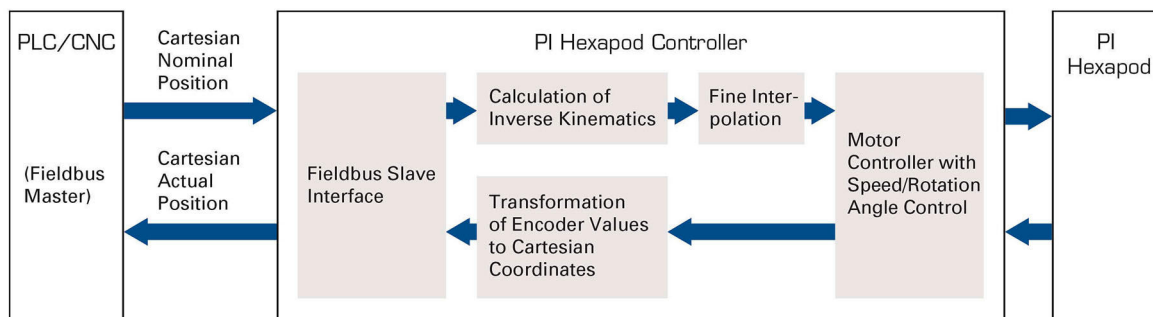

Integration of the hexapod motion controller into an automation system

Drawings / Images

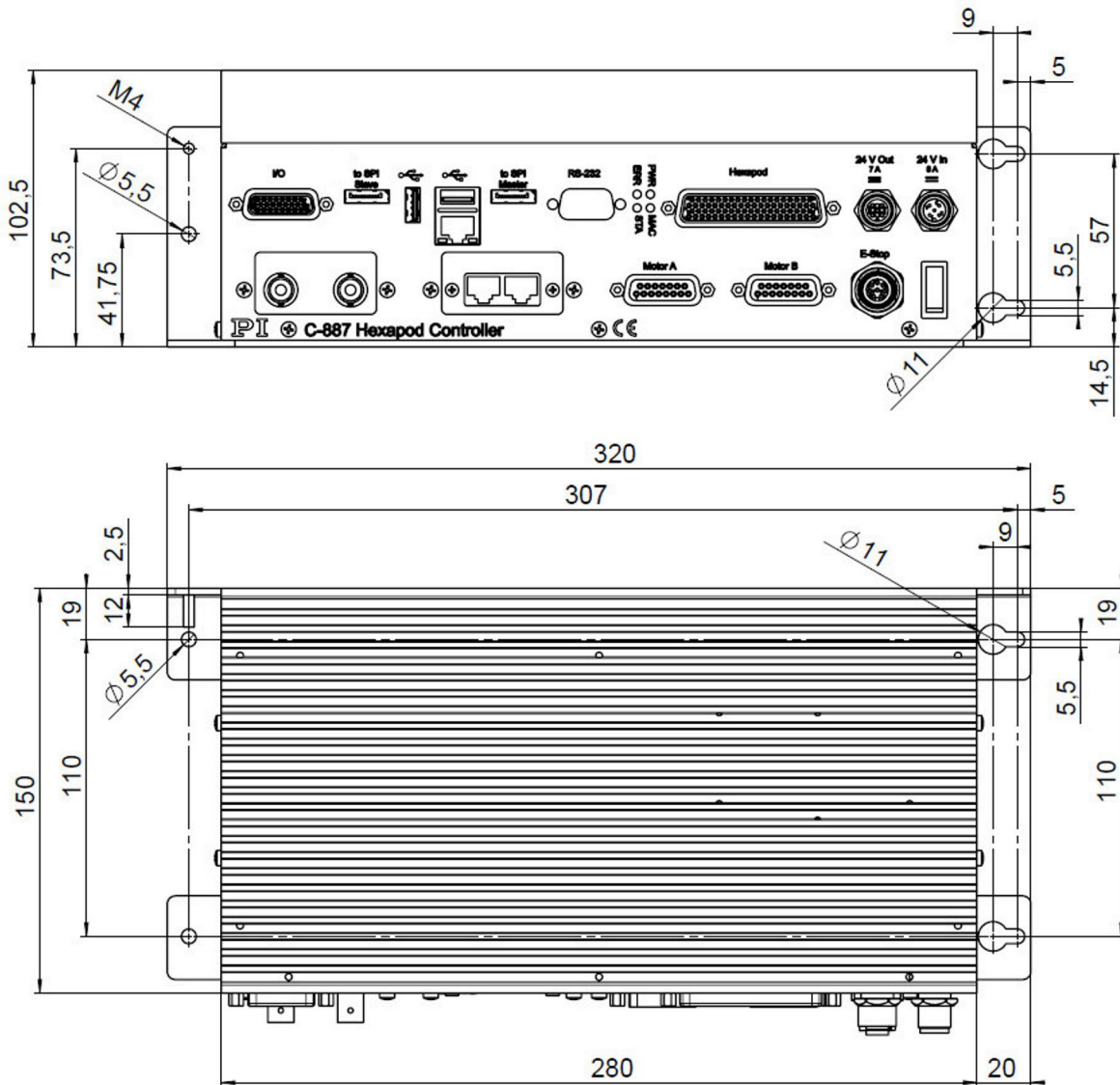

C-887.5xx, dimensions in mm. Version-dependent interfaces

Drawings / Images



Example configuration: H811.D2 miniature hexapod with C-887.532 motion controller with EtherCAT interface and motion stop. The EtherCAT master, here a Beckhoff controller, is provided and programmed by the customer.

Order Information

C-887.53

6-axis controller for hexapods, TCP/IP, RS-232, benchtop device, incl. control of two additional axes, EtherCAT® interface

C-887.531

6-axis controller for hexapods, TCP/IP, RS-232, benchtop device, incl. control of two additional axes, EtherCAT interface, analog inputs

C-887.532

6-axis controller for hexapods, TCP/IP, RS-232, benchtop device, incl. control of two additional axes, EtherCAT interface, motion stop

C-887.533

6-axis controller for hexapods, TCP/IP, RS-232, benchtop device, incl. control of two additional axes, EtherCAT® interface, motion stop, analog inputs