

PI Piezo Life Time Test Report

A. Bosotti, R. Paparella, F. Puricelli

1.	Introduction.....	3
1.1.	Vacuum.....	4
1.2.	Temperature.....	4
1.3.	Preload.....	4
1.4.	Driving signal.....	4
2.	General features and conceptual scheme.....	6
2.1.	Experimental setup.....	6
2.1.1.	The vertical cryostat.....	6
2.1.2.	The insert.....	7
2.1.3.	The piezoelectric actuator.....	8
2.1.4.	The test setup.....	9
2.2.	Main features of the test.....	11
3.	Test results.....	12
3.1.	Vacuum.....	12
3.2.	Temperature.....	12
3.3.	LN ₂ Evaporation.....	13
3.4.	Load.....	14
3.5.	Piezo behavior.....	14
3.5.1.	Electrical capacitance.....	15
3.5.2.	Anti-Resonance Frequency.....	15
3.5.3.	Hysteresis figure and max stroke.....	16
4.	Conclusions.....	17
5.	Appendix: schedule and run-time adjustments.....	18

1. Introduction

The purpose of this test is to investigate the behavior of piezoelectric ceramics in condition equivalent to 10 years of operation as actuator in active frequency tuner for ILC superconducting cavities (SC).

To do this a **Physik Instrumente PI P-888.90 PIC255** piezoelectric ceramic has been cooled down in LN₂ and has been excited uninterruptedly for a month up to its limits, sustaining about $1.5 \cdot 10^9$ cycles of switching, up to nearly the maximum stroke, a good estimate of ten years as actuator for ILC cavities.

The piezo is a good representative of the kind of ceramic to be used in active tuners at cryogenic temperatures. So even if this model will not be the final choice, the device to be used will not be substantially different from it for what concern the major characteristic of the ceramic (in the UMI tuner will be probably used a different actuator, with higher stroke and blocking force, but with ceramic properties close to the PI item).

During the test the piezo temperature and current were constantly monitored and, in order to emulate the working condition in the tuner, four parameters were considered:

- vacuum
- temperature
- preload
- driving signal

Some approximations were introduced for each one, mainly to overcome actual technical difficulties. They will be now discussed in detail.

1.1. Vacuum

The actuator, once installed, will operate inside the cryomodule in a region where an isolation vacuum has been made. The vacuum is necessary to avoid freezing of humidity on electric contacts making short circuits, and doesn't affect the piezo-ceramic behavior. The isolation vacuum will be granted in the chamber that hosts the piezo by a rotary pump. The pressure values will be reported in the following sections.

1.2. Temperature

In the actual cryogenic environment, the actuator is not placed in super fluid helium bath and so, considering that the tuner is installed under the 4K shield, the actuator temperature should be lying in a range from 2 to 4 K.

Because the lifetime test means a long period of cool down in vertical cryostat, using LHe would be very expensive. So, considering that the mechanical stresses for a ceramic are quite the same at 4K and at 77K, we have chosen to perform the lifetime test in LN₂ bath. Moreover, due to the liquid nitrogen higher thermal capacity, less refilling were needed, simplifying the test procedure.

1.3. Preload

It is widely proved that the correct value of preload grants a longer lifetime for this kind of piezoelectric actuators. For what concerns piezo theory, literature shows different values for the optimum preload, ranging from 20 to 50 percent of the maximum generated force value (i.e. blocking force).

We therefore use for this test an equipment capable of generating a known force on the piezo acting via a steel rod (see next chapter for details).

We choose, as a guideline, to keep the preload limited to 1 – 1.5 kN, with a reference value of 1.2 kN. This is also a reasonable estimation of the value expected for the actual system, where the actuator will receive the main part of its preload from the thermally shrunk cavity, acting as a spring load.

1.4. Driving signal

The main contribution to the actuator-driving signal, once installed, will be due to the need to compensate Lorentz Force Detuning with a feed-forward loop, driving the piezoelectric actuator with a signal that will be approximately as long as the whole RF pulse, i.e. 1.3 ms for TTF, at a repetition rate up to 10 Hz.

While the exact shape of the signal needs to be finely developed in the real machine, we choose to keep the pulse duration, while switching to use a sinusoidal waveform.

Finally, in order to reach quickly the wanted number of cycles count, the frequency of the signal was shifted up (in three steps) to 997 Hz (about 1 ms period, less time to complete $1.5 \cdot 10^9$ cycles).

The choice for an odd value grants the possibility to have phase-locked measurements without interfering power supply noise.

Regarding the voltage amplitude of the signal, a full range operation is usually not recommendable but in the real system high stroke will be required. Balancing these factors the amplitude was at the end limited to 10% - 90% of the maximum applicable voltage sweep.

2. General features and conceptual scheme

The facility for the lifetime test has been developed starting from the devices already in use at LASA laboratory for piezo and load cell characterization. Main elements will be now introduced in details.

2.1. Experimental setup

2.1.1. The vertical cryostat

The test was hosted by a vertical cryostat from Criotec. Picture, scheme and its main features follow.

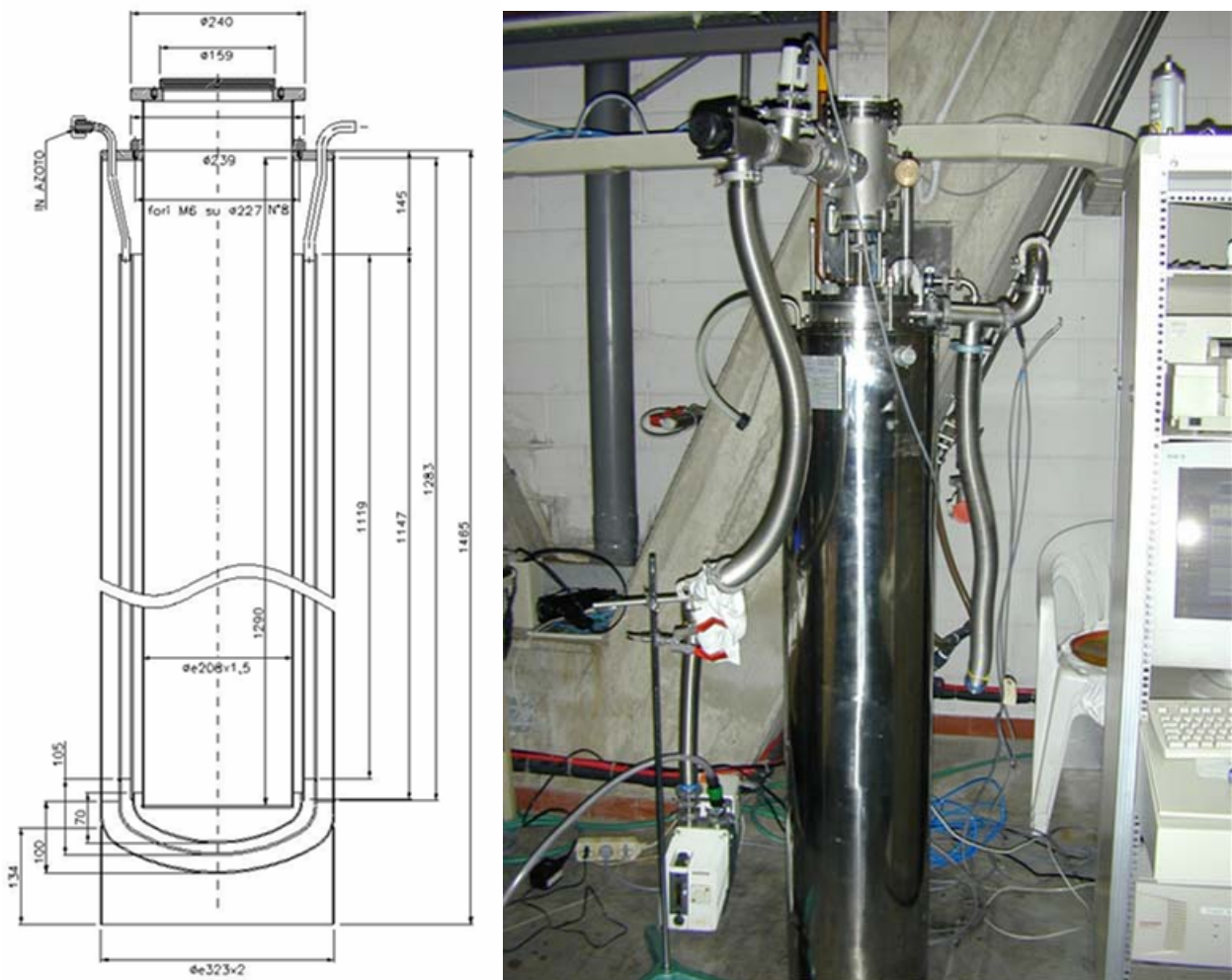

Fig. 1. The vertical cryostat used for our tests (right) and its technical drawing (left)

Manufacturer	Criotec
Nominal Temperature	2K
Max. Working pressure	0.5 bar
Isolation	N₂ shield

Table 1. Main features of our vertical cryostat

2.1.2. The insert

The insert used in this test comes from our previous cryogenic measurements on different piezos and load cells. Its main purpose is to exert a known force up to 2.5 kN on the device under test (i.e. the PI piezo), while hosting it in a cryogenic environment. To do this a steel chamber that hosts the device, placed at the bottom of the insert (fig. 2), is cooled down by immersion in the cryogenic bath while an external pump generates isolation vacuum inside it.

The mechanical load on the device is generated outside the cryostat, at the opposite side of the insert, by a spring mechanism (fig. 2) in which washers are coupled to a moving unit. The wanted force is generated simply screwing it down. This force is then transferred to the piezo by a steel rod extending for all the length of the insert and measured by a calibrated load cell working at room temperature. Great care has been devoted in avoiding shear or torsional forces that could seriously damage the device under test. This was accomplished using a proper guide that hosts the actuator. Also the length of the steel rod (1.3 m), strictly bounded in a guide too, guarantees that only longitudinal components of the force are transferred to the piezo.



Fig. 2. Upper side of the insert with the device used to generate the load on piezo (right). Steel chamber placed at the bottom of the insert and that contains the piezo during the test (left)

The conceptual and the detailed drawing of the insert are shown in the next pictures.

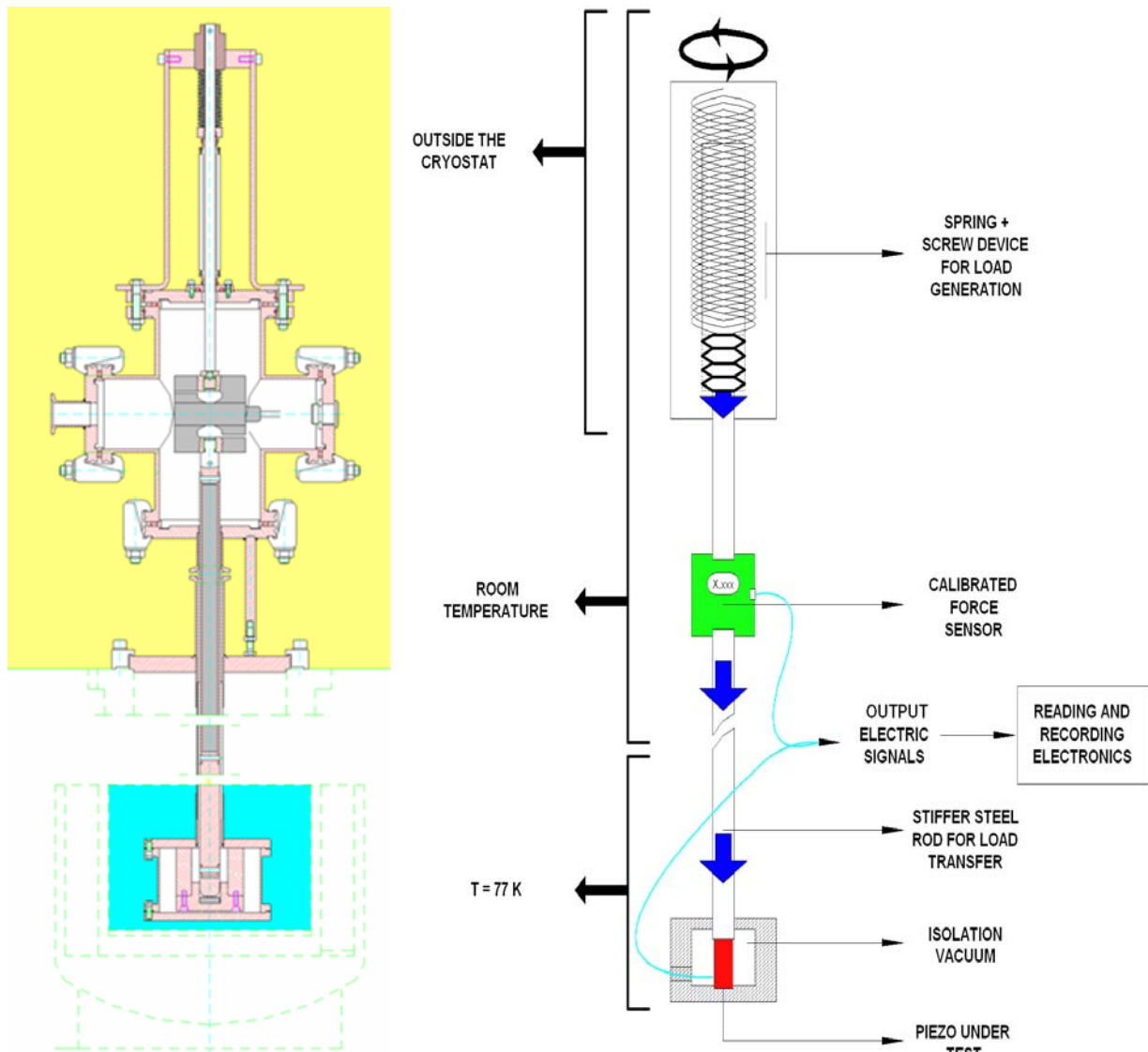

Fig. 3. Conceptual (right) and detailed (left) drawing of the insert used to test the piezo

2.1.3. The piezoelectric actuator

After one year of R&D on many piezo samples from different firms, essentially two models were looked at as possible choices to be installed in the UMI tuner, *Physik Instrumente PI P-888.90 PIC255* and *Noliac SCMAS/S1/A*. The first model was used for the test having bought a large number of it at a low cost, due to an agreement between the CARE collaboration and PI.

Anyway, for both actuators must be considered that the final piezo on the tuner may not be identical to the one available for tests (at least for the UMI tuner). Definitive stacks will keep exactly the same electro-mechanical intrinsic characteristics but will actually be longer, because higher stroke will be needed. Anyway this aspect it's not so relevant for the lifetime test whose validity is therefore preserved.

In the following table the main proprieties of the PI piezo are resumed.

PROPERTIES	PI P-888.90	Unit
Material	PZT-PIC 255	
Case/preload	No	
Length	36	mm
Cross section	100	mm ²
Young modulus	48,3	kN/mm ²
Stiffness	0,105	kN/um
Max. stroke	35	µm
Blocking force	3600	N
Res. frequency @ no load	40	kHz
Density	7,8 x 10 ³	kg/m ³
Min. voltage	-20	V
Max. voltage	120	V
Capacity - nominal	12,4	µF
Capacity - measured	13,6	µF
Loss Factor	0,015	Tanδ

Table 2. Main features and parameters of the tested piezo

2.1.4. The test setup

The whole setup of the test facility has been designed in order to acquire different simultaneous measurements:

- **setup status:**
 - temperature outside the insert
 - isolation vacuum pressure
- **piezo status:**
 - drive current flow
 - drive voltage
 - generated force
 - temperature
- **ancillaries:**
 - load to piezo
 - liquid to gas N₂ total evaporate

Here follows the scheme of the complete test facility, as it was set when the test started.

Not reported in the scheme of figure 4, a standard flux meter was connected to the cryostat in order to have a measure of the liquid N₂ evaporation, flowing outside the cryostat.

Both the inner chamber and the outer N₂ shield of the cryostat were connected to the counter so the flux measured results from the sum of the two.

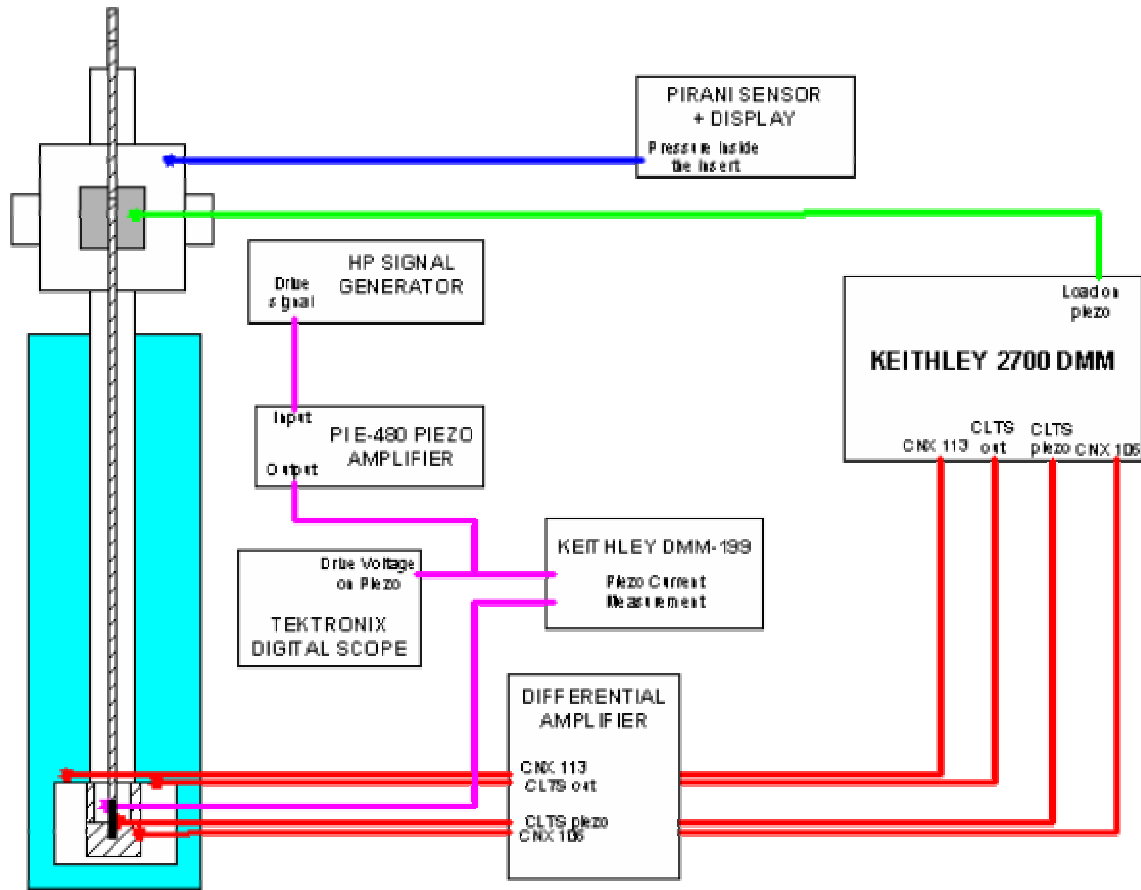

Fig. 4. Complete scheme of the experimental apparatus

2.2. *Main features of the test*

As previously mentioned, the goal of the test was to achieve $1.5 \cdot 10^9$ working cycles for the piezo under test. During run time, the test required continuous adjustments, mainly in order to refill the cryogenic liquid and keep the exerted force value close to the average value chosen.

In order to avoid unwanted damage to piezo due to high current flow, the frequency of the driving signal was increased slowly and in 3 steps, in this way a more accurate check was possible.

Basics layout of the test has been resumed in the following table 3.

Detailed results are finally showed in the following chapter (Paragraph 3).

Start	26 Nov 2004
Stop	20 Dec 2004
Hours	622
Cycles	$1.505 \cdot 10^9$
Frequency	117 Hz for 4 days 497 Hz for 6 days 997 Hz for 16 days
Average Preload	1.25 kN
Average Temperature	81 K

Table 3. Main features of the life time test

3. Test results

In the next paragraphs we discuss in detail the experimental data obtained from the test.

3.1. Vacuum

As we have already said in paragraph 1.1 a rotary pump granted the vacuum condition. The pressure inside the piezo box was measured by a Pirani sensor and its value has been stable at about 2×10^{-3} mbar for all the test time.

3.2. Temperature

As already shown in paragraph 1.2, there were four temperature sensors in our insert: two CLTS (one on the piezo and the other outside the box) and two CERNOX (one inside and the other outside the box).

The exact record of the T values was made difficult by the piezo driving amplifier that added a lot of unwanted (and unexpected!) common mode noise. Above filtering, sometimes we were forced to switch off the driver to check if we were recording the right values.

The temperature trends in the cryostat and inside the box have been grouped in the following picture:

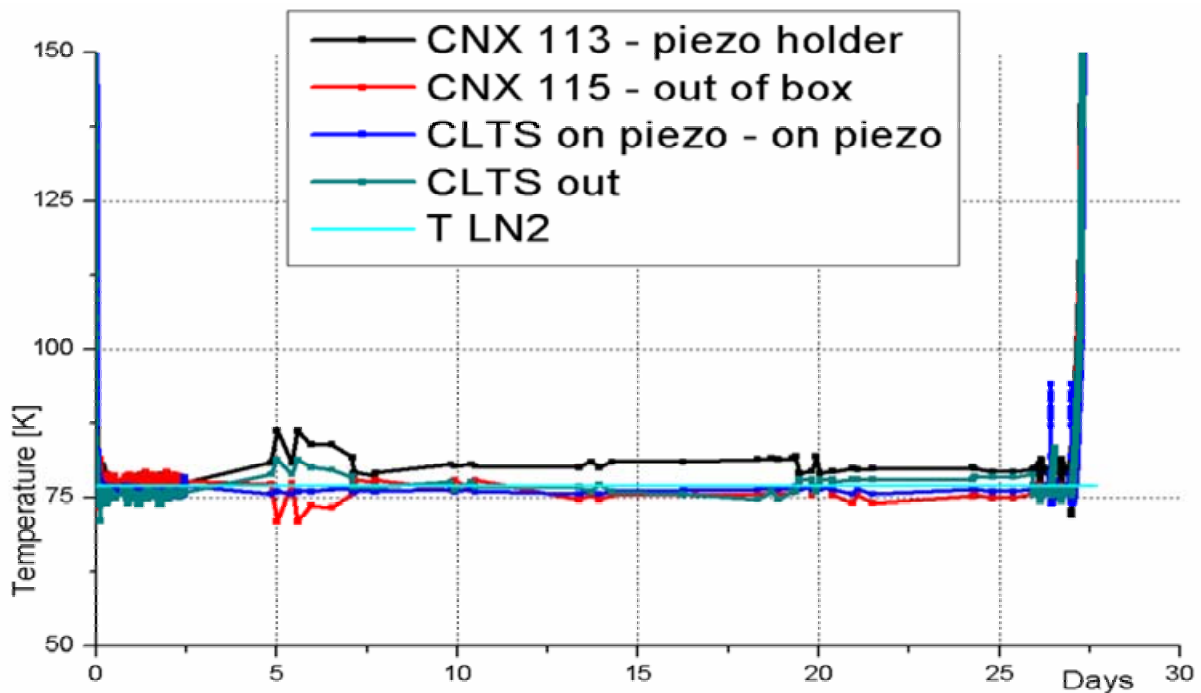

Fig. 5. Temperature trends recorded during the test

From the figure above, one can see that all temperatures have been quite stable for all the test duration: variations are small and are mainly due to the LN₂ low level in the cryostat just before we refill it. This last consideration is evident because the CLTS on piezo, which was the less sensitive to this phenomenon, is the most stable and presents an average value at about 80K. Even due to the high heat capacity of LN₂ and good DUT thermal equilibrium, no critical self-heating was recorded.

3.3. LN₂ Evaporation

The LN₂ evaporation rate measurements were made with a standard flux meter; in particular the instrument counter was reset at every refilling of the cryostat (to normalize every measure). Obtained data are shown in fig. 6:

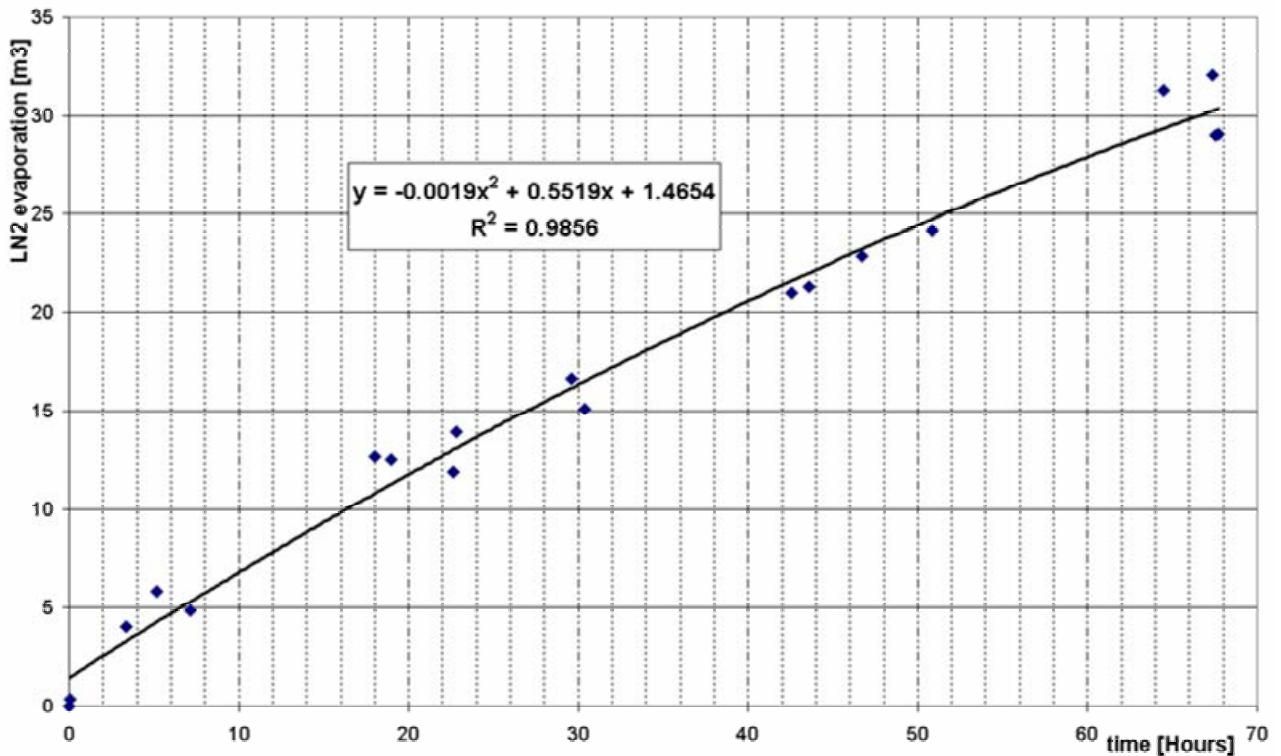

Fig. 6. LN₂ evaporation trend

We observe that our graph doesn't have the asymptotic trend that one could expect. This is due to the fact that such behavior is evident only for longer times: our interpolating function has to be considered as an approximation of the real trend for very short times.

3.4. Load

The historical graph of the applied preload on the piezo is shown in the figure

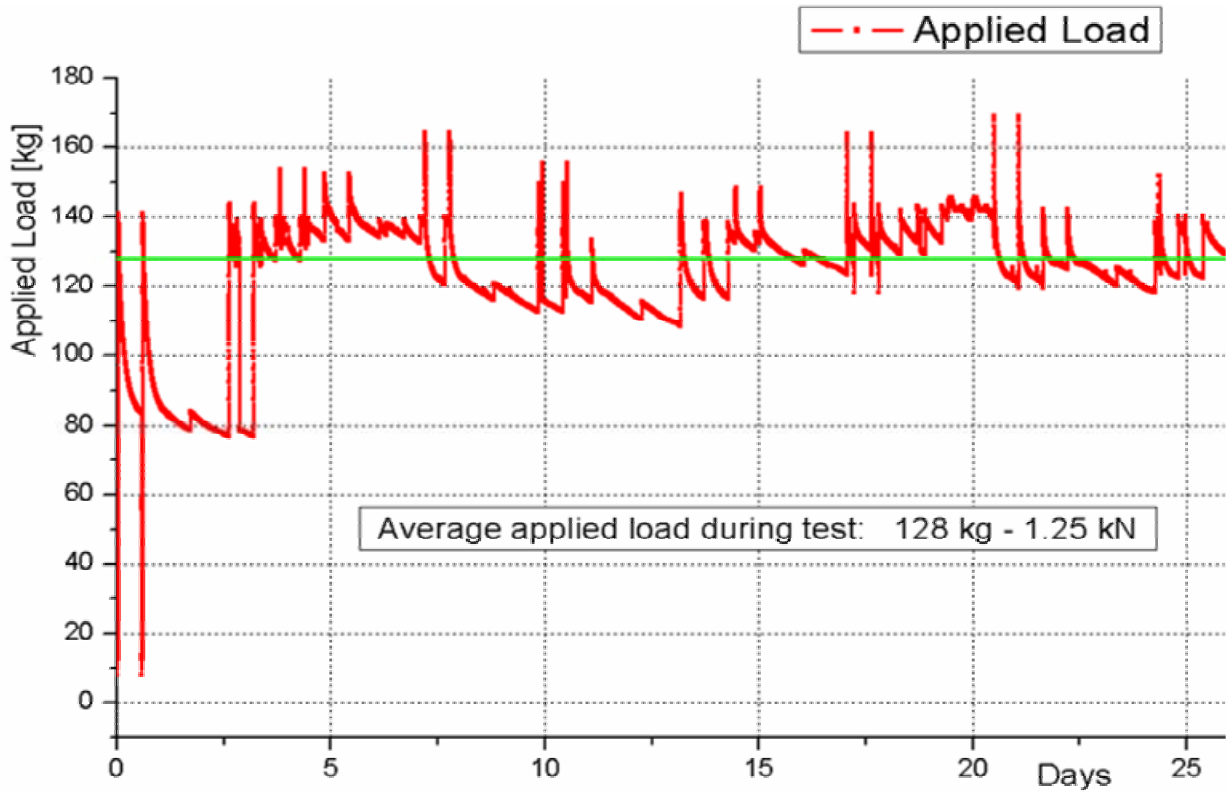

Fig. 7. Load applied to the piezo during the test

The saw-tooth shape is due to mechanical relaxations and successive readjustment of the piezo preload.

During test the average preload on test was about 128 kg (1.25 kN).

3.5. Piezo behavior

The lifetime test was performed not only to see long times piezo failures, but also to check any variation of piezo main parameters after ten years of stresses. So before and after test the following parameters were measured at room temperature:

- electrical capacitance
- resonance frequency
- hysteresis figure
- maximum stroke.

3.5.1. Electrical capacitance

The electrical capacitance has been measured for the unloaded piezo with a test bench capacitance meter. The values obtained are:

<i>BEFORE TEST</i>	<i>AFTER TEST</i>
<i>13.6 μF</i>	<i>13.56 μF</i>

Table 4. Electrical piezo capacitance measured before and after the life time test

3.5.2. Anti-Resonance Frequency

Also in this case we measured the resonance frequency for the unloaded piezo. The circuit analysis was then made with a Stanford Research Signal Analyzer SR785: the piezo was connected to form a voltage divider with a resistor as is shown in figure 8.

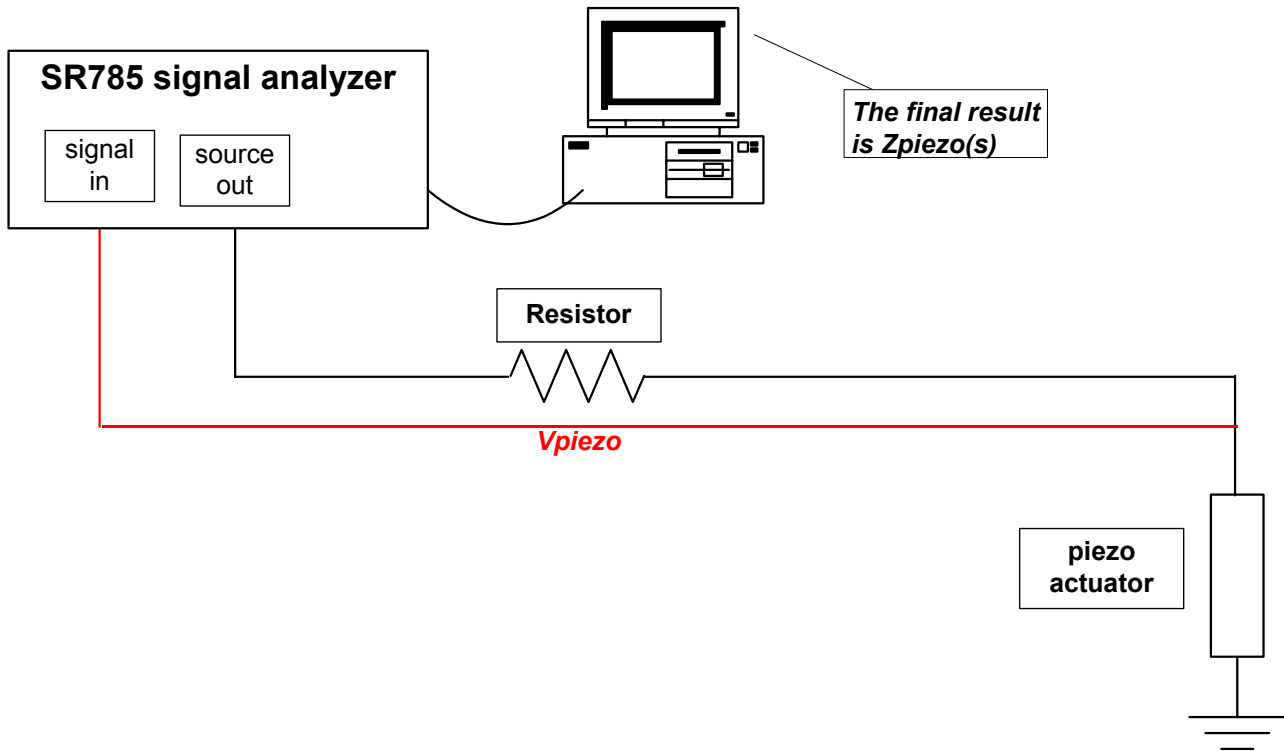

Fig. 8. Circuit scheme used to calculate the piezo impedance

The instrument is used in the network analysis mode: amplitude and phase are recorded. The piezo impedance can be calculated from the relation $R \frac{G(s)}{1 - G(s)}$, where $G(s) = \frac{V_{piezo}(s)}{V_{in}(s)}$.

Our results are shown in the following table:

<i>BEFORE TEST</i>	<i>AFTER TEST</i>
<i>45.94 kHz</i>	<i>45.2 kHz</i>

Table 5. Piezo anti-resonance frequency comparison

3.5.3. Hysteresis figure and max stroke

Hysteresis figures have been measured for an unloaded piezo. The measure is performed sweeping the piezo driving voltage amplitude and recording at the same time the stroke with a Linear Voltage Differential Transformer (LVDT) position transducer. The bottom of the piezo is bound, while the LVDT core is glued at the piezo top.

Moreover, because of the definition of *max stroke* as the displacement for an unloaded piezo when the supply voltage range is as large as the piezo can tolerate, we chose to set the input voltage amplitude range between the minimum and the maximum value recommended by piezo data sheets (in our case from -20V to 120V). In this way it was possible to deduce the max stroke parameter directly from hysteresis figures.

The obtained data are shown in figure 9.

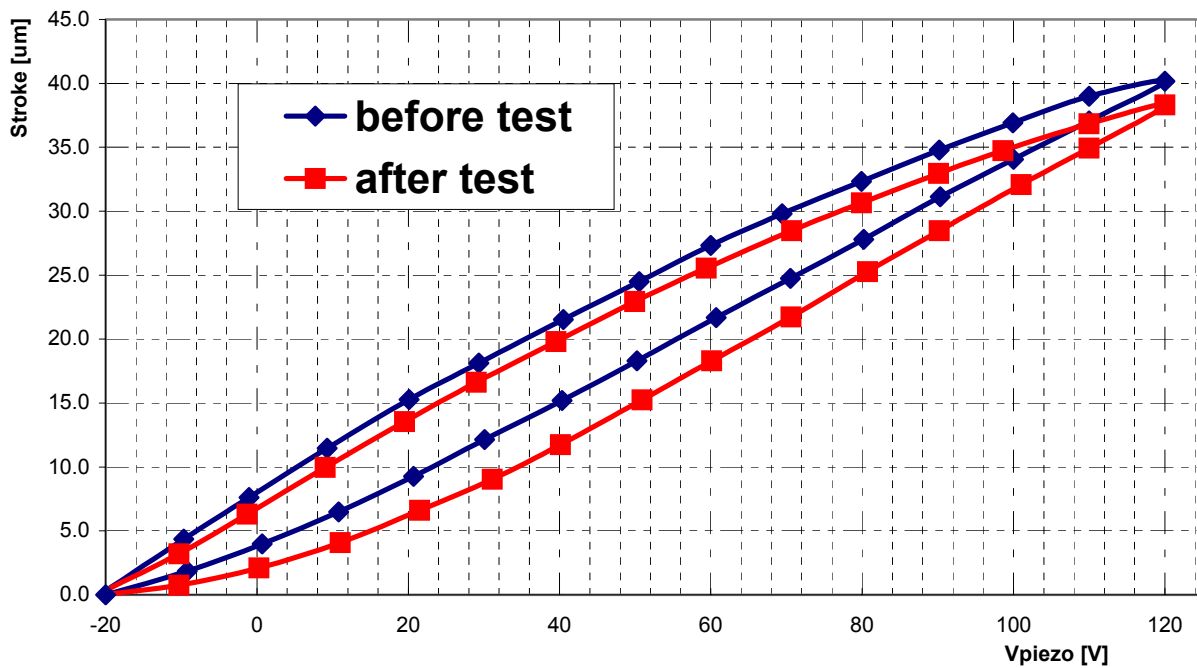

Fig. 9. Hysteresis figure comparisons

<i>MAXIMUM STROKE</i>	
<i>BEFORE TEST</i>	<i>AFTER TEST</i>
<i>40.2 µm</i>	<i>38.3 µm</i>

Table 6. Maximum stroke measured before and after test

4. Conclusions

After one month of operation in LN₂ environment in extreme conditions, the equivalent of ten years of switching in ILC active tuning systems, the piezo is still working.

Data and graphs exposed in paragraph 3, show that the piezo under test doesn't have any significant variation both of electrical (*capacity* and *resonance frequency*), mechanical (*max stroke*) and electromechanical properties (*hysteresis figure*). Therefore, from this point of view, we can expect that the actuator has enough lifetime for ILC operation, provided to avoid any stresses in directions different from the longitudinal one.

About this we are going to do some comments:

- our experiment has been made in an environment that is quite different from the one that will be in the accelerator. In fact while the test pressure is a good approximation of the cryomodule condition, this is not true for what concerns the temperature, (see paragraph 1.2). Anyway mechanical strains and stresses on piezo produced by the cryogenic environment are about the same at 77K and 4K.
- Even if this actuator will not be placed in the UMI tuner, a similar one will be employed. So this test has also validity for this case.

5. Appendix: schedule and run-time adjustments

During the 26 days of the test no critical element arise, just the ordinary maintenance was needed. It is now reported (table 7) an extract of the log diary of the test.

Log file	Relative sample	Absolute sample	Time	Current to piezo	Freq.	Cycles	Vmin	Vmax	LN2 refuellings
			[Days]	[mA] rms	[Hz]		[Volt]	[Volt]	
26_11_04 (I part)	640	640	0,0		117	4,04 E+05	0	100	
	42000	42000	2,6	32	117	2,65 E+07	0	100	
	44840	44840	2,8	32	117	2,83 E+07	0	100	
	59950	59950	3,7	32	117	3,79 E+07	0	100	
	60160	60160	3,8	33	117	3,80 E+07	0	100	
	61060	61060	3,8	33	117	3,86 E+07	0	100	Start
	61390	61390	3,8	33	117	3,88 E+07	0	100	Stop
	62230	62230	3,9	35	117	3,93 E+07	0	100	
26_11_04 (II part)	77540	77540	4,8	117	487	4,90 E+07	0	100	
	77733	77733	4,9	120	487	4,95 E+07	0	100	Start
	77870	77870	4,9	120	487	4,99 E+07	0	100	Stop
	80342	80342	5,0	119	497	5,64 E+07	-6	102	
	95490	95490	6,0	118	497	9,70 E+07	-5,6	102	
	98050	98050	6,1	114	497	1,04 E+08	-5,6	102	
	113120	113120	7,1	119	497	1,44 E+08	-5,6	102	
	113530	113530	7,1	117	497	1,45 E+08	-5,6	102	
3_12_04 (I part)	1710	115261	7,2	122	497	1,50 E+08	-5,6	102	Start
	1985	115536	7,2	125	497	1,51 E+08	-5,6	102	Stop
	43690	157241	9,8	120	497	2,63 E+08	-5,6	102	Start
	44570	158121	9,9	120	497	2,65 E+08	-5,6	102	Stop
	45160	158711	9,9	119	497	2,67 E+08	-4,4	107	
3_12_04 (II part)	55450	169001	10,6	123	497	2,94 E+08	-4,4	107	
9_12_04	0	211054	13,2	189	997	4,07 E+08	-7,2	103	Start
	180	211234	13,2	189	997	4,08 E+08	-7,2	103	Stop
	2720	213774	13,4	189	997	4,22 E+08	-7,2	103	
	8295	219349	13,7	195	997	4,52 E+08	-7,2	103	
	20250	231304	14,5	193	997	5,16 E+08	-7,2	103	Start

	20560	231614	14,5	195	997	5,18 E+08	-7,2	103	Stop
13_12_04	190	273017	17,1			7,41 E+08			Start
	290	273117	17,1	198	997	7,41 E+08	-7,2	103	Stop
	2765	275592	17,2	196	997	7,55 E+08	-7,2	103	
	20105	292932	18,3	197	997	8,48 E+08	-7,2	103	
	26290	299117	18,7	195	997	8,81 E+08	-7,6	102	
	36920	309747	19,4	193	997	9,39 E+08	-7,6	103	
	44225	317052	19,8	187	997	9,78 E+08	-7,6	102	
16_12_04	0	328030	20,5			1,04 E+09			Start
	170	328200	20,5	190	997	1,04 E+09	-7,6	102	Stop
	6770	334800	20,9	187	997	1,07 E+09	-7,6	102	
	18490	346520	21,7	193	997	1,14 E+09	-7,6	102	
	60030	388060	24,3	192	997	1,36 E+09	-7,6	102	
	61060	389090	24,3	190	997	1,37 E+09	-7,6	102	
	61600	389630	24,4	189	997	1,37 E+09	-7,6	102	Start
	61745	389775	24,4	189	997	1,37 E+09	-7,6	102	Stop
20_12_04	0	390175	24,4	195	997	1,37 E+09	-7,6	102	
	6820	396995	24,8	192	997	1,41 E+09	-7,6	102	
	8210	398385	24,9	192	997	1,42 E+09	-7,6	102	
	24475	414650	25,9	188	997	1,50 E+09	-7,6	102	

Table 7. Life time test time schedule