

# P-726 PIFOC® High-Load Objective Scanner

## High-Dynamic Piezo Z Scanner for Heavy Objectives

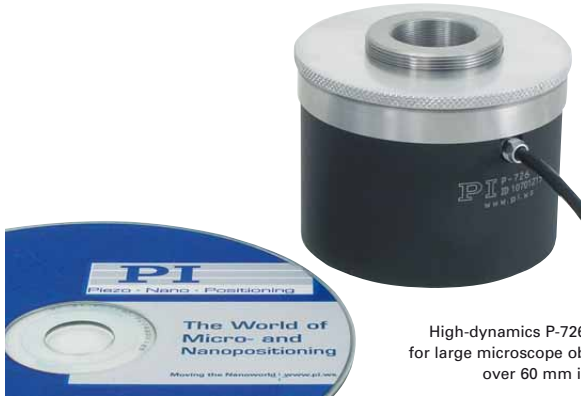

High-dynamics P-726 PIFOC® for large microscope objectives over 60 mm in length

- High-Dynamics Positioning and Scanning for Large Objectives
- 1120 Hz Resonant Frequency, 560 Hz with 210 g Load
- Typical Settling Time about 6 ms
- Travel Range 100 μm
- Direct-Metrology Capacitive Sensors for Best Linearity, Stability and Control Dynamics
- Resolution to 0.3 nm
- Frictionless, High-Precision Flexure Guiding System for Better Focus Stability

The P-726 PIFOC® Nanofocusing system was developed to achieve the fastest possible stepping time with the heavy, high-numerical-aperture objectives used in many of today's high-resolution microscopy applications. Its extremely stiff design offers excellent settling time and scanning frequency values even when objectives of several hundred grams are moved. High stiffness is

achieved with the rotationally symmetric arrangement of multiple piezo drives and the optimized design of the flexure and lever elements, which assure the excellent guiding accuracy and dynamics.

Furthermore, like other members of the PIFOC® family, the P-726 is equipped with direct metrology capacitive position sensors that allow resolutions far below one nanometer.

### Application Examples

- 3-D Imaging
- Screening
- Autofocus systems
- Microscopy
- Confocal microscopy
- Surface analysis
- Wafer inspection

### Direct Metrology with Capacitive Sensors for Highest Stability and Accuracy

PI's proprietary capacitive position sensors measure the actual motion of the moving part relative to the stationary base (direct metrology). Errors in the drive train, actuator, lever arm or in guiding system do not influence the measurements. The result is exceptional

motion linearity, higher long-term stability and a stiffer, more-responsive servo loop, because external influences are immediately recognized by the sensor. Due to this sensor principle, the P-726 features a resolution of under 0.4 nm in closed-loop and a linearity of 0.02%.

### Simple Installation with QuickLock Thread Options

The PIFOC® is mounted between the turret and the objective with the QuickLock thread adapter. After threading the adapter into the turret, the QuickLock is affixed in the desired position. Because the PIFOC® body need not to be rotated, cable wind-up is not an issue.

### Ceramic Insulated Piezo Actuators Provide Long Lifetime

Highest possible reliability is assured by the use of award-winning PICMA® multilayer piezo actuators. PICMA® actuators are the only actuators on the market with ceramic-only

### Ordering Information

**P-726.1CD**  
High-Dynamics PIFOC® Piezo Nanofocusing Z-Drive, 100 μm, Capacitive Sensor

#### QuickLock Thread Adapter as Accessories:

**P-726.04**  
P-726 PIFOC® Thread Adapter M28 x 0.75

**P-726.05**  
P-726 PIFOC® Thread Adapter M32 x 0.75

**P-726.06**  
P-726 PIFOC® Thread Adapter M26 x 1/36"

**P-726.11**  
P-726 PIFOC® Thread Adapter M25 x 0.75

**P-726.12**  
P-726 PIFOC® Thread Adapter W0.8 x 1/36"

Ask about custom designs!

insulation, which makes them resistant to ambient humidity and leakage-current failures. They are thus far superior to conventional actuators in reliability and lifetime.

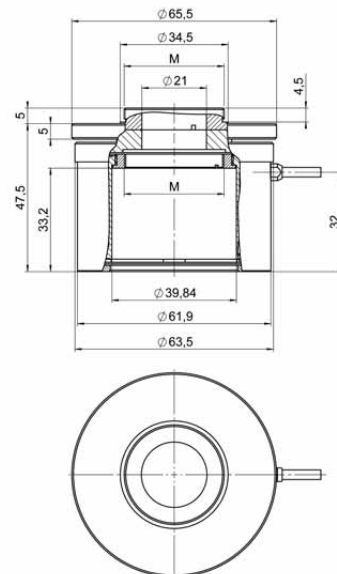

P-726 dimensions in mm with P-726.05 M32 QuickLock adapter

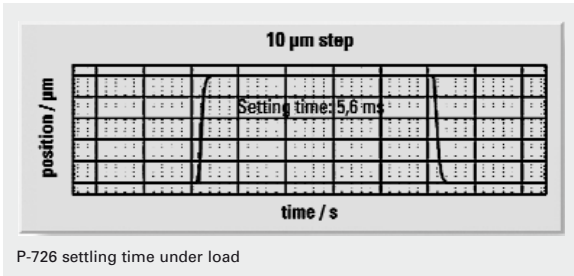

P-726 settling time under load

### Technical Data

	P-726.1CD	Tolerance
Active axes	Z	
<b>Motion and positioning</b>		
Integrated sensor	Capacitive, direct metrology	
Closed-loop travel	100 µm	calibrated
Closed-loop resolution	0.4 nm	typ.
Open-loop resolution	0.3 nm	typ.
Linearity, closed-loop	0.02 %	typ.
Repeatability	±3 nm	typ.
Runout $\Theta_x, \Theta_y$	±5 µrad	typ.
Crosstalk X, Y	50 nm	typ.
<b>Mechanical properties</b>		
Stiffness in motion direction	3.4 N/µm	±20 %
Unloaded resonant frequency	1120 Hz	±20 %
Resonant frequency under load	560 Hz @ 210 g	±20 %
Resonant frequency under load	480 Hz @ 310 g	±20 %
Push/pull force capacity in motion direction	100 / 50 N	Max.
<b>Drive properties</b>		
Piezo ceramic type	PICMA® P-885	
Electrical capacitance	6 µF	±20 %
Dynamic operating current coefficient	7.5 µA/(Hz · µm)	±20 %
<b>Miscellaneous</b>		
Operating temperature range	-20 to 80 °C	
Material	Aluminum, steel	
Dimensions	Diameter: 65 mm, Height: 50.7 mm	
Max. objective diameter	M32	
Mass	575 g	±5 %
Cable length	1.5 m	±10 mm
Sensor / voltage connection	Sub-D Special	
Recommended controller / amplifier	Single-channel digital controller: E-753 (bench-top) (p. 2-108) E-625 bench-top controller (p. 2-114), E-665 high-power bench-top controller (p. 2-116) E-500 modular piezo controller system (p. 2-142) with E-505 high-power amplifier module (p. 2-147) and E-509 servo-controller (p. 2-152)	
<b>System properties</b>		
System configuration	E-500 modular piezo controller system with E-505 high-power amplifier module and E-509 servo-controller 310 g load (objective mass)	
Closed-loop amplifier bandwidth, small signal, 10 µm	130 Hz	
Closed-loop amplifier bandwidth, large signal	70 Hz	

### Linear Actuators & Motors

### Nanopositioning / Piezoelectrics

### Piezo Flexure Stages / High-Speed Scanning Systems

Linear

### Vertical & Tip/Tilt

2- and 3-Axis

6-Axis

Fast Steering Mirrors / Active Optics

Piezo Drivers / Servo Controllers

Single-Channel

Multi-Channel

Modular

Accessories

Piezoelectrics in Positioning

### Nanometrology

### Micropositioning

### Index



# PIFOC® Long Range Objective Scanning System

## 1000 µm Travel, with PiezoWalk® Drive, Controller & Software



The microscopy package: Objective nanofocusing system with 1 mm travel range and adapters for M25 threads. The controller comes with an extensive software package e. g. for automation and also supports manual control via joystick

- **High Force and Long Travel Range: 10 N / 1 mm**
- **Dynamic Fine Positioning, Typical Step and Settle: 20 ms**
- **Drive Resolution < 1 nm, Linear Encoder Resolution 20 nm**
- **Self Locking at Rest, no Heat Generation, No Servojitter**
- **Compact Design: Ø 48 mm, 40.5 mm Height**
- **Frictionless, High-Precision Flexure Guiding System for Better Focus Stability**
- **Complete System with Controller**
- **Non-Volatile Macro Storage for Stand-Alone Functionality with Autostart Macro**
- **I/O for Automation, Joystick for Manual Operation**

The NEXACT® objective scanner provides significantly more travel range than other piezo-driven objective positioners due to its unique PiezoWalk® linear motor drive. This drive combines high stiffness, quick step-and-settle, large travel ranges and extreme position stability.

### Application Examples

- Two-photon microscopy
- Confocal microscopy
- 3-D Imaging
- Screening
- Autofocus systems
- Surface analysis
- Wafer inspection

The long travel range of 1 mm is the main reason why the objective scanner offers decisive advantages for applications with large optical penetration depth such as two-photon microscopy. The focusing plane can be selected as desired over the total working range of the objective without any changes to the mechanical system. In conjunction with a step-and-settle time of less than 20 ms this increases the through-put and allows rapid Z-stack acquisition.

### Simple Installation with Quick-Lock Thread Options

The PIFOC® is mounted between the turret and the objective with the QuickLock thread adapter. After threading the

adapter into the turret, the QuickLock is affixed in the desired position. Because the PIFOC® body need not to be rotated, cable wind-up is not an issue.

### Controller for Manual Control and Automated Scans

The system comes with a proprietary closed-loop controller for NEXACT® piezomotor linear drives. A joystick can be connected as a manual control. Its non-volatile memory supports macro programming, e.g. to speed up automation tasks. A user-programmable „Auto-start“ macro allows for stand-alone-functionality without the need for external communication. The system includes an extensive software package to facilitate integration into com-

### Ordering Information

#### ND72Z9LAQ

PIFOC® Piezo Nanofocusing Z-Drive with NEXACT® Linear Motor, 1 mm, Linear Encoder, 20 nm Resolution, M25 QuickLock Thread Adapters, Including Controller

#### Accessories:

##### P-721.91Q

Extens. Tube, 12.5 mm, Thread M25 x 0.75

##### C-819.20

2-Axis Analog Joystick

plex imaging applications and also allows manual control via a joystick.

In addition, four input and four output lines are provided for easy synchronization of motion with internal or external trigger signals.

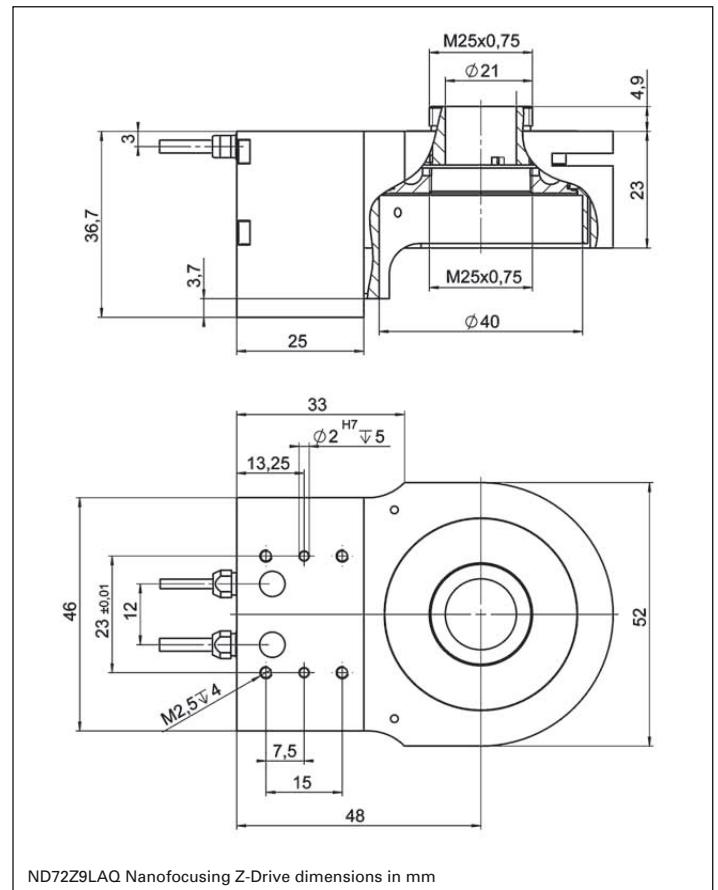

### Easy System Set-up, Comprehensive Software Package

All parameters can be set and checked via software. For system setup and configuration the versatile PIMikroMove user-interface software is included. Interfacing to custom software is facilitated with LabView drivers and DLLs.

### Scanners for Higher Resolution and Larger Loads

PI offers a range of related PIFOC® objective scanners with different specifications. The P-725 models e.g. (s.p. 2-28) offer resolutions of less than one nanometer. For larger loads

and dynamic scanning applications the models P-726 (s.p. 2-32) and P-725.DD (s.p. 2-30) are also available with travel ranges of up to 100 µm.

### NEXACT® PiezoWalk® Technology

See page 1-12 for further information.

The products described in this document are in part protected by the following patents:  
German Patent No. P4408618.0

## Technical Data

<b>Model</b>	<b>ND72Z9LAQ</b>
	Long-travel objective scanning system, incl. controller
Active axes	Z
<b>Motion and positioning</b>	
Travel range	1 mm
Integrated sensor	Linear encoder
Sensor resolution	20 nm
Linearity, closed-loop	0.1 %
Bidirectional repeatability	50 nm
Runout (X, Y) typ.	15 µrad / 100 µm
Step and settle (200 nm) typ.	20 ms
Max. velocity	10 mm/s
<b>Mechanical properties</b>	
Stiffness in motion direction	0.5 N/µm
Max. push / pull force (active)	10 N
Drive resolution	< 1 nm
<b>Drive properties</b>	
Drive type	NEXACT® linear drive
<b>Controllers</b>	
Communication interfaces	USB 1.0, RS-232 (9-pin (m) sub-D)
I/O ports	4 analog/digital in, 4 digital out (TTL)
User software	PIMikroMove®, PI Terminal
Software drivers	GCS-DLL, LabVIEW Driver
Supported functionality	Digital setting of the control parameters on-the-fly; start-up macro; data recorder for recording parameters such as motor input voltage, velocity, position or position error; internal safety circuit: watchdog timer
<b>Miscellaneous</b>	
Operating temperature range	0 to 50 °C
Material Scanner	Aluminum
Weight	440 g (scanner), 1.1 kg (controller)
Cable length to controller	1.5 m
Dimensions controller	206 x 130 x 66 mm (including mounting rails)