

P-612 XY Piezo Nanopositioning System

Compact, Clear Aperture



P-612.2SL XY piezo stage (CD for size comparison)

- **Compact: Footprint 60 x 60 mm**
- **100 x 100 μm Closed-Loop Travel Range (130 x 130 Open-Loop)**
- **For Cost-Sensitive Applications**
- **Clear Aperture 20 x 20 mm**
- **Parallel-Kinematics for Enhanced Responsiveness / Multi-Axis Precision**
- **Outstanding Lifetime Due to PICMA[®] Piezo Actuators**
- **Z-Stage Also Available**

The P-612.2SL is a piezo-based nanopositioning system featuring a compact footprint of only 60 x 60 mm and a height of 18 mm. Due to the 20 x 20 mm open aperture, the system is excellently suited for sample positioning in microscopy or scanning applications. Equipped with piezo drives and zero-stiction, zero-friction flexure guiding system, the series provides nanometer-range resolution and millisecond response time. A Z stage with the same form factor is available for vertical positioning applications (see P-612.ZSL p. 2-38).

Cost-Effective Design

Flexures optimized with Finite Element Analysis (FEA) are used to guide the compact, low-cost stage. Flexures allow extremely high-precision motion, no matter how minute, as they are completely free of play and fric-

tion. They also optimize stiffness in and perpendicular to the direction of motion.

Position Servo-Control with Nanometer Resolution

High-resolution, broadband, strain gauge sensors (SGS) are applied to appropriate locations on the drive train and measure the displacement of the moving part of the stage relative to the base directly. The SGS sensors assure optimum position stability in the nanometer range and fast response.

The open-loop models are ideal for applications where fast response and very high resolution are essential, but absolute positioning is not important. They can also be used in applications where the position is controlled by an external linear position sensor such as an interferometer, a PSD (position sen-

Ordering Information

P-612.2SL

XY Nanopositioning System with 20 x 20 mm Aperture, 100 x 100 μm , Strain Gauge Sensors

P-612.20L

XY Nanopositioning System with Aperture 20 x 20 mm, 100 x 100 μm , Open-Loop

sitive diode), CCD chip / image processing system, or the eyes and hands of an operator.

Ceramic Insulated Piezo Actuators Provide Long Lifetime

Highest possible reliability is assured by the use of award-winning PICMA[®] multilayer piezo actuators. PICMA[®] actuators are the only actuators on the market with ceramic-only insulation, which makes them resistant to ambient humidity and leakage-current failures. They are thus far superior to conventional actuators in reliability and lifetime.

System properties

System configuration	P-612.2 SL and E-500 modular system with E-503 amplifier and E-509 sensor module, 100 load
Amplifier bandwidth, small signal	45 Hz
Settling time (10% step width)	15 ms

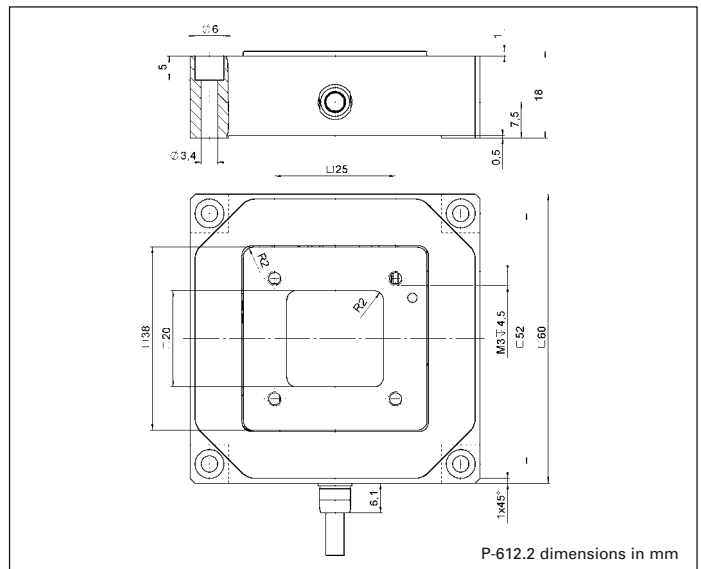

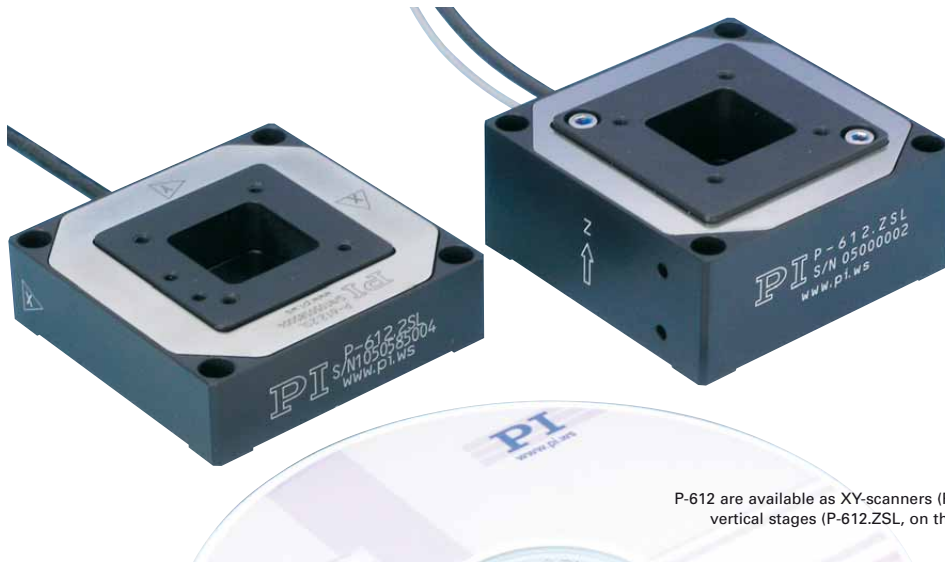

P-612 are available as XY-scanners (P-612.2SL, on the left) and vertical stages (P-612.ZSL, on the right) providing a travel range of 100 μm per axis

Technical Data

Model	P-612.2SL	P-612.20L	Units	Tolerance
Active axes	X, Y	X, Y		
Motion and positioning				
Integrated sensor	SGS	–		
Open-loop travel, -20 to +120 V	130	130	μm	min. (+20%/-0%)
Closed-loop travel	100	–		μm
Open-loop resolution	0.8	0.8	nm	typ.
Closed-loop resolution	5	–	nm	typ.
Linearity	0.4	–	%	typ.
Repeatability	<10	–	nm	typ.
Pitch	± 10	± 10	μrad	typ.
Yaw in X/ Y	$\pm 10 / \pm 50$	$\pm 10 / \pm 50$	μrad	typ.
Mechanical properties				
Stiffness	0.15	0.15	N/ μm	$\pm 20\%$
Unloaded resonant frequency	400	400	Hz	$\pm 20\%$
Resonant frequency @ 100 g	200	200	Hz	$\pm 20\%$
Push/pull force capacity in motion direction	15 / 5	15 / 5	N	Max.
Load capacity	15	15	N	Max.
Drive properties				
Ceramic type	PICMA® P-885	PICMA® P-885		
Electrical capacitance	1.5	1.5	μF	$\pm 20\%$
Dynamic operating current coefficient	1.9	1.9	$\mu\text{A}/(\text{Hz} \cdot \mu\text{m})$	$\pm 20\%$
Miscellaneous				
Operating temperature range	-20 to 80	-20 to 80	$^{\circ}\text{C}$	
Material	Aluminum, steel	Aluminum, steel		
Mass	105	105	g	$\pm 5\%$
Cable length	1.5	1.5	m	$\pm 10\text{ mm}$
Sensor connector	LEMO connector	–		
Voltage connection	LEMO connector	LEMO connector		

Resolution of PI Piezo Nanopositioners is not limited by friction or stiction. Noise equivalent motion with E-503 amplifier (p. 2-146)

Recommended controller

Single-channel (1 per axis): E-610 servo-controller / amplifier (p. 2-110) , E-625 servo-controller, bench-top (p. 2-114), E-621 controller module (p. 2-160)

Multi-channel: modular piezo controller system E-500 (p. 2-142) with amplifier module E-503 (three channels) (p. 2-146) or E-505 (1 per axis, high-power) (p. 2-147) and E-509 controller (p. 2-152)

Linear Actuators & Motors

Nanopositioning / Piezoelectrics

Piezo Flexure Stages / High-Speed Scanning Systems

Linear

Vertical & Tip/Tilt

2- and 3-Axis

6-Axis

Fast Steering Mirrors / Active Optics

Piezo Drivers / Servo Controllers

Single-Channel

Multi-Channel

Modular

Accessories

Piezoelectrics in Positioning

Nanometrology

Micropositioning

Index

P-612.Z Piezo Z Stage

Compact Nanopositioning Stage with Aperture



P-612.ZSL
compact nano-elevation stage with a
20 mm x 20 mm clear aperture

- Travel Range 100 μm
- Resolution to 0.2 nm
- Linearity 0.2 %
- Compact: Footprint 60 x 60 mm
- Very Cost-Effective Controller/Piezomechanics Systems
- Frictionless, High-Precision Flexure Guiding System
- Outstanding Lifetime Due to PICMA® Piezo Actuators

These elevation stages are cost-effective, compact, piezo-based positioning systems with travel ranges of 100 μm . The space-saving design features a footprint of only 60 x 60 mm. The 20 x 20 mm clear aperture makes them ideally suited for sample positioning in microscopy. Equipped with PICMA® piezo drives and zero-stiction, zero-friction flexure guiding system, the series pro-

Application Examples

- Interferometry
- Scanning microscopy
- Nanopositioning
- Biotechnology
- Quality assurance testing
- Semiconductor fabrication

vides nanometer-range resolution and millisecond response time.

Position Servo-Control with Nanometer Resolution

High-resolution, broadband, strain gauge sensors (SGS) are applied to appropriate locations on the drive train and measure the displacement of the moving part of the stage relative to the base. The SGS sensors assure optimum position stability in the nanometer range and fast response.

The open-loop models are ideal for applications where fast response and very high resolution are essential, but absolute positioning is not important. They can also be used when the position is controlled by an external sensor

such as an interferometer, a PSD (position sensitive detector), CCD chip / image processing system, or the eyes and hands of an operator.

High Reliability and Long Lifetime

The compact P-612 systems are equipped with preloaded PICMA® high-performance piezo actuators which are integrated into a sophisticated, FEA-modeled, flexure guiding system. The PICMA® actuators feature cofired ceramic encapsulation and thus provide better performance and reliability than conventional piezo actuators. Actuators, guiding system

Ordering Information

P-612.ZSL
Vertical Nanopositioning Stage,
100 μm , 20 x 20 mm Aperture,
SGS-Sensor

P-612.Z0L
Vertical Nanopositioning Stage,
100 μm , 20 x 20 mm Aperture,
No Sensor

and sensors are maintenance-free, not subject to wear and offer an extraordinary reliability.

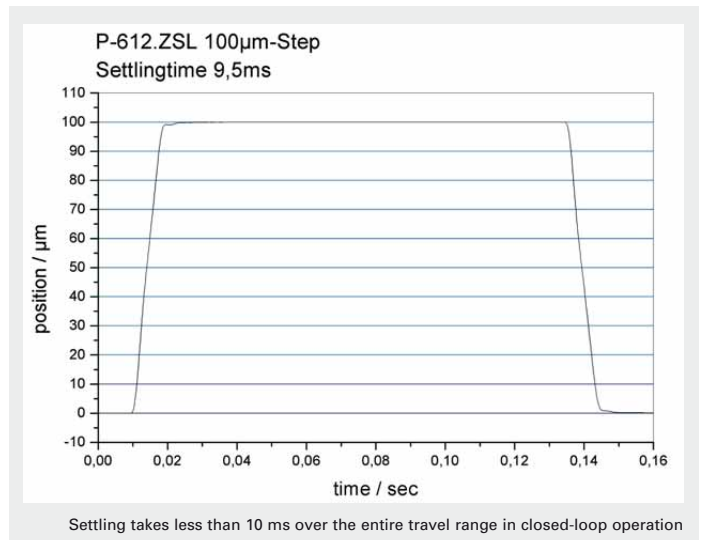

P-612s are available as XY-scanners (P-612.2SL, on the left) and vertical stages (P-612.ZSL, on the right) providing a travel range of 100 μm per axis

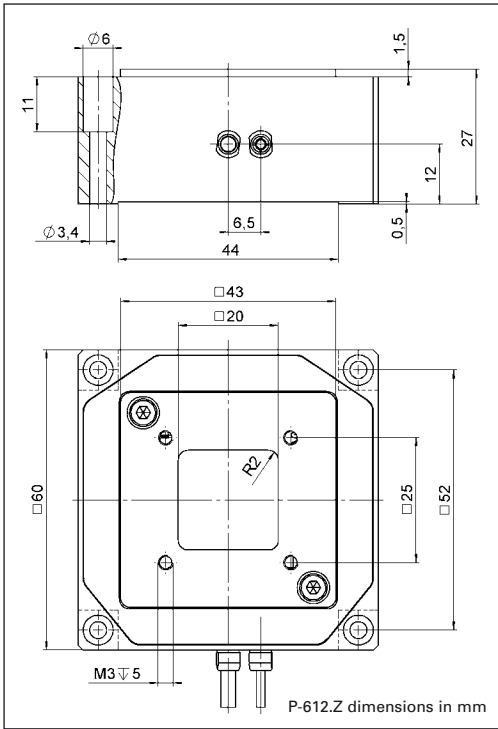

System properties

System configuration	P-612.ZSL and E-625.SR controller, 30 g load
Closed-loop amplifier small signal bandwidth	110 Hz
Closed-loop amplifier large signal bandwidth	80 Hz
Settling time (10% step width)	8 ms

Technical Data

Model	P-612.ZSL	P-612.Z0L	Units	Tolerance
Active axes	Z	Z		
Motion and positioning				
Integrated sensor	SGS	–		
Open-loop travel, -20 to +120 V	110	110	µm	min. (+20%/-0%)
Closed-loop travel	100	–	µm	calibrated
Open-loop resolution	0.2	0.2	nm	typ.
Closed-loop resolution	1.5	–	nm	typ.
Linearity, closed-loop	0.2	–	%	typ.
Repeatability	±4	–	nm	typ.
Runout θ_x, θ_y	±10	±10	µrad	typ.
Crosstalk X, Y	±20	±20	µm	typ.
Mechanical properties				
Stiffness in motion direction	0.63	0.63	N/µm	±20%
Unloaded resonant frequency	490	490	Hz	±20%
Resonant frequency under load	420 (30 g)	420 (30 g)	Hz	±20%
Load capacity	15 / 10	15 / 10	N	Max.
Drive properties				
Ceramic type	PICMA® P-885	PICMA® P-885		
Electrical capacitance	3	3	µF	±20%
Dynamic operating current coefficient	3.8	3.8	µA/(Hz • µm)	±20%
Miscellaneous				
Operating temperature range	-20 to 80	-20 to 80	°C	
Material	Aluminum	Aluminum		
Mass	0.28	0.275	kg	±5%
Cable length	1.5	1.5	m	±10 mm
Sensor / voltage connection	LEMO	LEMO (no sensor)		

Linear Actuators & Motors

Nanopositioning / Piezoelectrics

Piezo Flexure Stages / High-Speed Scanning Systems

Linear

Vertical & Tip/Tilt

2- and 3-Axis

6-Axis

Fast Steering Mirrors / Active Optics

Piezo Drivers / Servo Controllers

Single-Channel

Multi-Channel

Modular

Accessories

Piezoelectrics in Positioning

Nanometrology

Micropositioning

Index

Resolution of PI Piezo Nanopositioners is not limited by friction or stiction. Value given is noise equivalent motion with E-503 amplifier. (p. 2-146) Recommended controller / amplifier E-610 servo controller / amplifier card (p. 2-110), E-625 servo-controller, bench-top (p. 2-114), E-665 high-power servo-controller with display, bench-top (p. 2-116), E-660 bench-top for open-loop systems (p. 2-119)