

P-601 PiezoMove™ Z-Actuator

Flexure-Guided OEM Piezo Actuator with Long Stroke to 400 µm

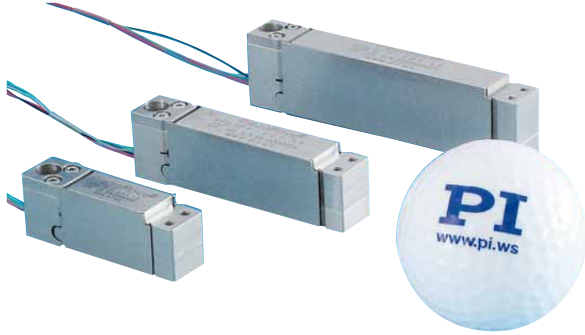

PiezoMove™ Lever-amplified piezo actuators of the P-601 series

- Flexure Guidance for Frictionless, Ultra-Straight Motion
- Travel Ranges to 400 µm
- Resolution to 0.2 nm
- High Dynamics and Stiffness
- Custom Designs with Longer Travel or Faster Response and Non-Magnetic Versions Feasible
- Outstanding Lifetime Due to PICMA® Piezo Actuators
- Choice of Closed-Loop and Open-Loop Models
- Ideal OEM Actuator for Precision Motion Control in Optics, Medical, Biotech and Microfluidics Applications

The flexure-guided, lever-amplified PiezoMove™ P-601 actuators provide large vertical travel ranges up to 400 µm, fast response and high positioning accuracy in a very small package. With settling times of only

a few milliseconds and a resolution in the sub-nanometer range they are well suited for both static and dynamic applications.

P-601 PiezoMove™ lever-amplified actuators cover the range between direct-driven pre-loaded piezo translators, such as the P-840 series (see p. 1-74) and single-axis nanopositioning stages, like the P-611 series (see p. 2-20). Compared to direct-driven piezo translators, lever-amplified actuators offer larger travel ranges and much higher lateral stiffness and guiding precision. Compared to single-axis nanopositioning stages, they offer significantly smaller sizes. PiezoMove™ lever-amplified actuators feature a resolution to 0.2 nm and a repeatability to 8 nm.

OEM Actuator with Integrated Guidance

With their highly precise, frictionless flexure guidance, a very high stiffness and excellent straightness of motion are achieved. Together with their small dimensions and the cost-effective design, the P-601 lever amplified actuators are especially suited for OEM applications. Versions with strain-gauge sensors (SGS) are equipped with a full bridge circuit that is insensitive to thermal drift. Versions without sensors are also available for open-loop applications such as in high-speed switches and pumps. In addition to the standard steel models, special invar and non-magnetic versions are available on request.

Ceramic Insulated Piezo Actuators Provide Long Lifetime

Highest possible reliability is assured by the use of award-winning PICMA® multilayer piezo actuators. PICMA® actuators are the only actuators on the market with ceramic-only insulation, which makes them resistant to ambient humidity and leakage-current failures. They are thus far superior to conventional actuators in reliability and lifetime.

Ordering Information

P-601.1S
PiezoMove™ OEM Flexure-Guided, Lever-Amplified Actuator, 100 µm, SGS-Sensor

P-601.3S
PiezoMove™ OEM Flexure-Guided, Lever-Amplified Actuator, 250 µm, SGS-Sensor

P-601.4S
PiezoMove™ OEM Flexure-Guided, Lever-Amplified Actuator, 400 µm, SGS-Sensor

P-601.1SL
PiezoMove™ OEM Flexure-Guided, Lever-Amplified Actuator, 100 µm, SGS-Sensor, LEMO Connector

P-601.3SL
PiezoMove™ OEM Flexure-Guided, Lever-Amplified Actuator, 250 µm, SGS-Sensor, LEMO Connector

P-601.4SL
PiezoMove™ OEM Flexure-Guided, Lever-Amplified Actuator, 400 µm, SGS-Sensor, LEMO Connector

P-601.10
PiezoMove™ OEM Flexure-Guided, Lever-Amplified Actuator, 100 µm, Open-Loop

P-601.30
PiezoMove™ OEM Flexure-Guided, Lever-Amplified Actuator, 250 µm, Open-Loop

P-601.40
PiezoMove™ OEM Flexure-Guided, Lever-Amplified Actuator, 400 µm, Open-Loop

Application Example

- Nanopositioning
- Imaging
- High-speed switching
- Patch clamp
- Micro-dispensing
- Semiconductor testing
- Adaptronics / Automation
- Photonics / integrated optics
- Biotechnology

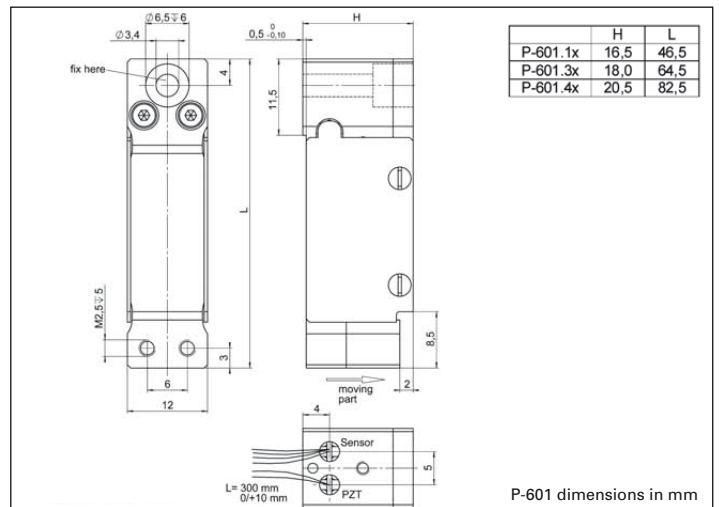

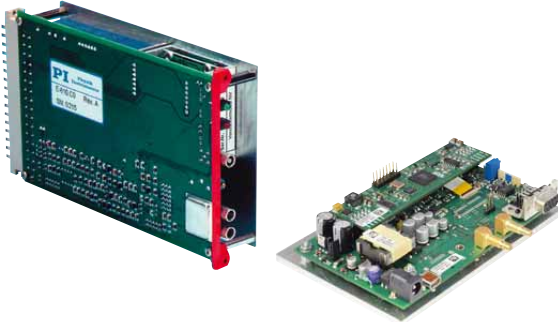

The E-610 analog controller OEM module left or the E-609 digital OEM controller are available for closed-loop versions with position sensor

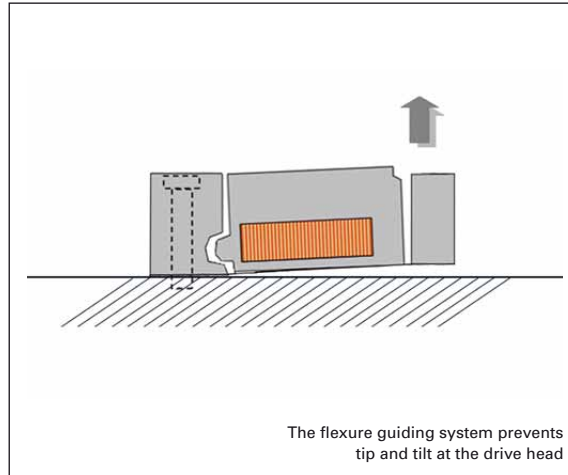

Linear Actuators & Motors

PiezoWalk® Motors / Actuators

PLine® Ultrasonic Motors

DC-Servo & Stepper Actuators

Piezo Actuators & Components

Guided / Preloaded Actuators

Unpackaged Stack Actuators

Patches/Benders/Tubes/Shear..

Nanopositioning/Piezoelectrics

Nanometrology

Micropositioning

Index

Technical Data

Model	P-601.1S P-601.1SL	P-601.3S P-601.3SL	P-601.4S P-601.4SL	P-601.x0 Open-loop versions	Units	Tolerance
Active axes	Z	Z	Z	Z		
Motion and positioning						
Integrated sensor	SGS	SGS	SGS	–		
Open-loop travel, -20 to +120 V	100	250	400	as P-601.xS	µm	min. (+20%/0%)
Closed-loop travel	100	250	400	–	µm	calibrated
Open-loop resolution	0.2	0.3	0.4	as P-601.xS	nm	typ.
Closed-loop resolution	2	6	12	–	nm	typ.
Linearity, closed-loop	0.1	0.3	0.3	–	%	typ.
Repeatability	8	10	30	–	nm	typ.
Runout θ_x, θ_y	20 / 10	20 / 10	20 / 10	as P-601.xS	µrad	typ.
Mechanical properties						
Stiffness in motion direction	0.8	0.38	0.28	as P-601.xS	N/µm	±20 %
Unloaded resonant frequency	750	440	350	as P-601.xS	Hz	±20 %
Resonant frequency @ 30 g	620	350	290	as P-601.xS	Hz	±20 %
Push/pull force capacity in motion direction	30/10	20/10	15/10	as P-601.xS	N	Max.
Lateral force	30	30	30	as P-601.xS	N	Max.
Drive properties						
Ceramic type	PICMA® P-885	PICMA® P-885	PICMA® P-885	as P-601.xS		
Electrical capacitance	1.5	3.1	4.6	as P-601.xS	µF	±20 %
Dynamic operating current coefficient	1.9	1.6	1.4	as P-601.xS	µA/(Hz•µm)	±20 %
Miscellaneous						
Operating temperature range	-20 to 80	-20 to 80	-20 to 80	-20 to 80	°C	
Material	Stainless steel	Stainless steel	Stainless steel	Stainless steel		
Mass without cables	0.05	0.08	0.11	as P-601.xS	kg	±5 %
Cable length	S-version: 0.3 SL-version: 1.5	S-version: 0.3 SL-version: 1.5	S-version: 0.3 SL-version: 1.5	0.3	m	±10 mm
Sensor / voltage connection	S-version: open leads SL-version: LEMO	S-version: open leads SL-version: LEMO	S-version: open leads SL-version: LEMO	Open leads (no sensor)		

Recommended controller / amplifier
E-610 controller / amplifier (p. 2-110), E-625 bench-top controller (p. 2-114)

P-603 PiezoMove Linear Actuator

Low-cost and with Large Travel Ranges



P-603 linear actuators with 500 and 100 μm travel range (from left to right). CD for size comparison

- Frictionless, High-Precision Flexure Guiding System
- Travel Ranges to 500 μm
- Cost-Effective Design
- Outstanding Lifetime Due to PICMA® Piezo Actuators
- Available with Integrated Position Sensor
- Ideal OEM Actuators for Precision Motion Control in Optics, Medical, Biotech and Microfluidics Applications
- Custom Designs with Larger Travel or Faster Response and Non-Magnetic Versions Feasible

P-603 PiezoMove flexure-guided piezo actuators integrate a frictionless high-efficiency motion amplifier to combine large

travel ranges up to 500 μm with high stiffness and very fast response. The flexure guides reduce tip at the drive head to a minimum saving the cost for additional guiding systems when integrating these actuators in micro-dispensing devices, pumps or servo valves. The overall precision of 10s of nanometers also makes these devices ideal for nanomanipulation applications.

Options and Custom Versions

For OEM applications, PiezoMove actuators can be modified in various ways to suit the customer's requirements. The stiffness and force generation can be influenced via the lever design and the dimensions of the piezo ceramics used in the actuator. If only a small force and low guiding accuracy are required, large strokes of seven-

ral 100 μm and high frequencies can be achieved with small actuators, e.g. for micropump drives. For high-accuracy applications, an integrated position feedback sensor is available. The actuators were designed to allow for considerable cost savings in large production runs.

OEM Control Electronics

PI also supplies a variety of controllers to match the actuators. These range from simple amplifier modules (see p. 2-164) and analog closed-loop OEM controllers (see p. 2-110) to high-performance digital controllers (see p. 2-100ff). The great choice of actuators and controllers allows customers to select the optimum combination of performance and cost for their application.

Increased Lifetime Through Humidity Resistance

The monolithic ceramic-encapsulated design provides better humidity protection than polymer-film insulation. Diffusion of water molecules into the insulation layer is greatly reduced by the use of cofired, outer ceramic encapsulation. Due to their high resonant frequency the actuators are suitable for highly dynamic applications with small loads; depending on the load an external preload for

Ordering Information

PiezoMove® OEM Linear Actuator with High Stiffness

- 1 Travel Range 100 μm
- 3 Travel Range 300 μm
- 5 Travel Range 500 μm

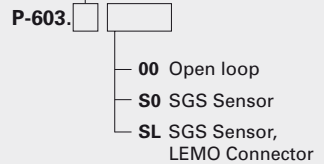

Ask about custom designs!

dynamic applications is recommended. The high Curie temperature of 320° gives PICMA® actuators a usable temperature range extending up to 150 °C, far beyond 80°C as is common for conventional multilayer actuators. With conventional multilayer actuators, heat generation – which is proportional to operating frequency – either limits the operating frequency or duty cycle in dynamic operation, or makes ungainly cooling provisions necessary. At the low end, operation down to a few Kelvin is possible (with reduced travel range).

Application Example

- Nanopositioning
- CCD / CMOS camera technology / Micro scanning
- Cell manipulation, biohandling
- Medical technology
- Micropumps
- Micro-dispensing
- Slit width adjustment
- Cavity Tuning
- Beam stabilization
- Photonics / integrated optics
- Switches

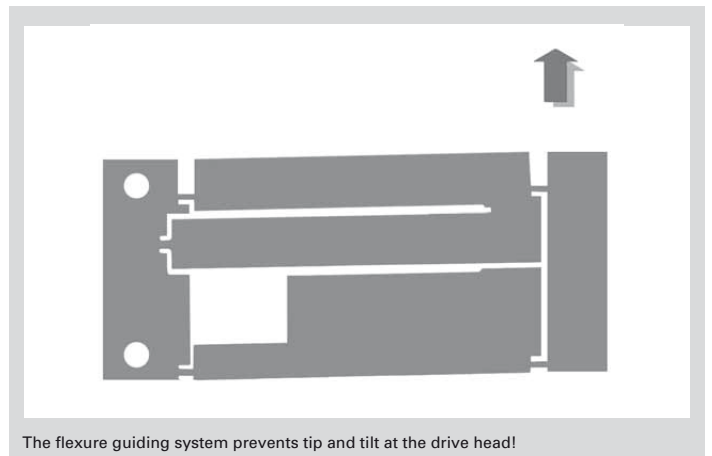

The flexure guiding system prevents tip and tilt at the drive head!



Levels of Integration: From Stack Actuator to 6-Axis Stage

	Stack actuators	Lever-amplified actuators	Positioning systems
Travel ranges	up to approx. 150 μm	up to 1 mm	up to 2 mm
Axes moved	one	one	up to three linear axes and three tip/tilt axes
Sensors	SGS optional	SGS optional	SGS or direct measuring capacitive sensors
Linearity	up to 99.8 %	up to 99.8 %	over 99.9 %
Guidance	none	flexures for rotations <10°	flexures for rotations <2°
Space required	low	low	depends on features
Price	low	low	depends on features
Integration effort	high	low	low

Flexure guided, lever-amplified actuators form a reasonably priced and easily integrated class of products between conventional piezo stack actuators and the complex piezo nanopositioning systems

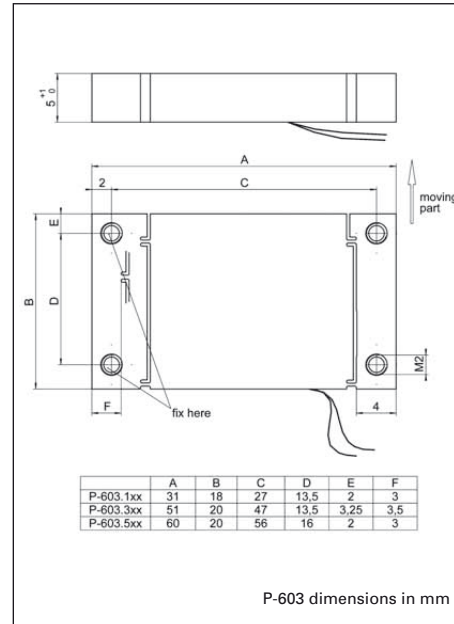

Linear Actuators & Motors

PiezoWalk® Motors / Actuators

PILine® Ultrasonic Motors

DC-Servo & Stepper Actuators

Piezo Actuators & Components

Guided / Preloaded Actuators

Unpackaged Stack Actuators

Patches/Benders/Tubes/Shear..

Nanopositioning / Piezoelectrics

Nanometrology

Micropositioning

Index

Technical Data (preliminary)

Model	P-603.1S0 P-603.1SL	P-603.3S0 P-603.3SL	P-603.5S0 P-603.5SL	P-603.x00 open-loop versions	Units	Tolerance
Active axes	X	X	X	X		
Motion and positioning						
Integrated sensor	SGS	SGS	SGS	–		
Open-loop travel, -20 to +120 V	100	300	550	as P-603.xS0	μm	min. (+20%/-0)
Closed-loop travel	100	300	500	–	μm	calibrated
Open-loop resolution	0.2	0.3	0.4	as P-603.xS0	nm	typ.
Closed-loop resolution	2	4	7.5	–	nm	typ.
Linearity, closed-loop	0.3	0.3	0.3	–	%	typ.
Repeatability	8	10	30	–	nm	typ.
Mechanical properties						
Stiffness in motion direction	0.25	0.14	0.06	as P-603.xS0	N/ μm	$\pm 20\%$
Unloaded resonant frequency	900	450	300	as P-603.xS0	Hz	$\pm 20\%$
Push/pull force capacity in motion direction	20 / 2.5	15 / 2	10 / 1.5	as P-603.xS0	N	max.
Blocking force	20	35	25	as P-603.xS0	N	max.
Drive properties						
Ceramic type	PICMA® P-885	PICMA® P-885	PICMA® P-885	PICMA® P-885		
Electrical Capacitance	1.5	3.1	3.7	as P-603.xS0	μF	$\pm 20\%$
Dynamic operating current coefficient	1.9	1.3	1.6	as P-603.xS0	$\mu\text{A}/(\text{Hz}\cdot\mu\text{m})$	$\pm 20\%$
Miscellaneous						
Operating temperature range	-20 to 80	-20 to 80	-20 to 80	-20 to 80	$^{\circ}\text{C}$	
Material	Stainless steel	Stainless steel	Stainless steel	Stainless steel		
Mass	0.02 / 0.031	0.032 / 0.043	0.038 / 0.049	as P-603.xS0	kg	$\pm 5\%$
Cable length	0.5	0.5	0.5	0.5	m	$\pm 10\text{ mm}$
Sensor / voltage connection	S-version: open leads SL-version: LEMO connector (SGS Sensor)	S-version: open leads SL-version: LEMO connector (SGS Sensor)	S-version: open leads SL-version: LEMO connector (SGS Sensor)	Open leads		

Recommended controller / amplifier

E-610 controller / amplifier see p. 2-110, E-625 bench-top controller see p. 2-114