

N-381 NEXACT® Linear Actuator, Manipulator, Piezo Stepper

High-Resolution PiezoWalk® Linear Actuator with Optional Position Sensor

N-381 piezo stepper linear actuator for sample positioning and manipulation provides long travel, high speed and very high resolution; shown with E-861 NEXACT® Controller



- **Travel Range 30 mm**
- **Zero-Wear Piezo Stepping Drive, Ideal for Micro- and Nano-Manipulation**
- **Integrated Linear Encoder Option for Highest Accuracy with 20 nm Resolution**
- **Very High Acceleration, e.g. for Cell Penetration**
- **Two Operating Modes: Continuous Stepping Mode and Continuously Variable, High-Dynamics Analog Mode for 30 µm Resolution****
- **Up to 10 N Force Generation**
- **Self Locking at Rest, no Heat Generation**
- **Smooth Motion, no Closed-Loop Jitter**
- **Vacuum-Compatible and Non-Magnetic Versions**

The compact N-381 linear actuators are ideal drives and micro manipulators e.g. for biotechnology and nanotechnology applications. Rapid accelerations, velocities of 10 mm/s

and forces up to 10 N enable high-dynamics and throughput for automation tasks. The PiezoWalk® drive principle allows long travel ranges and fast oscillations of 7 µm amplitude with frequencies up to several 100 Hz. This “analog mode” can be used to provide rapid acceleration, e.g. in cell penetration applications, or smooth motion for dynamic laser tuning or even for active damping of oscillations. Two models are available: The N-381.3A model is equipped with a high-resolution position sensor, allowing sub-micrometer repeatability in closed-loop operation. The N-381.30 open-loop version is intended for high precision applications where the absolute position is

not important or is controlled by an external loop (video, laser, quadcell, etc.).

Piezo Stepping Drive — the Multi-Functional Piezo Linear Motor

A great advantage characteristic of the NEXACT® piezo stepping drive is its dual-mode operating principle combining the best features of other piezo motor designs, such as high resolution, high force and high speed into one compact unit. At the target position the drive requires no current and generates no heat while providing long-term, nanometer stability. This autolocking feature also completely eliminates servo-jitter as it occurs with other

Ordering Information

N-381.3A
NEXACTUATOR® Linear Actuator, 30 mm, 20 nm Encoder Resolution

N-381.30
NEXACTUATOR® Linear Actuator, 30 mm, Open-Loop

Available on request

Ask about custom designs!

closed-loop motors. Since motion is not based on dynamic friction as with piezo inertial drives (stick-slip-motors) but solely caused by the nanometer precise motion of clamped piezo actuators, there is no wear to limit the lifetime. When operated in closed-loop, excellent velocity control is achieved.

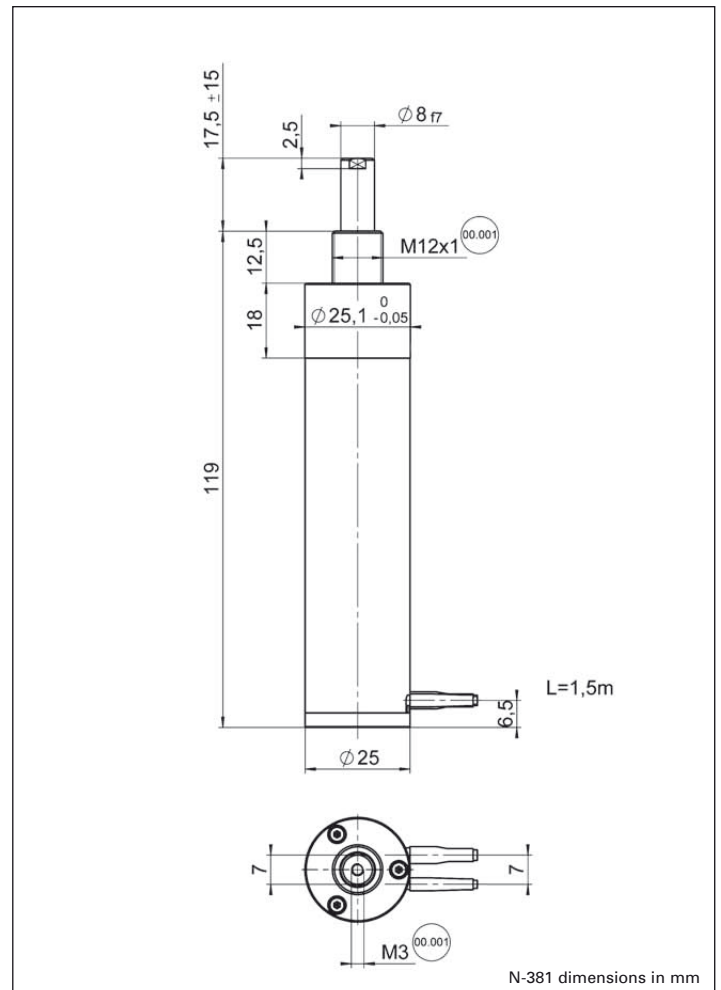

N-381 dimensions in mm

Application Examples

- Drive unit for scanning stage
- Cell manipulation, biohandling
- Micromanipulation
- Life science
- Photonics
- Laser tuning
- Motion in strong magnetic fields

Working Principle for Application Flexibility

NEXACT® PiezoWalk® technology overcomes the limitations of conventional nanopositioning drives and combines virtually unlimited travel ranges with high stiffness in a very small package. Furthermore, NEXACT® actuators provide piezo-class resolution (far below one nanometer) and millisecond responsiveness. The special drive design reduces the operating voltage to 45 V and below.

In operation, piezoceramic bending elements act on the runner, which is connected to the moving part of the application. The length of the runner determines the travel range

and can be chosen as required. To move the runner over longer distances the stepping mode is used, whereas for distances smaller than one step, the analog mode enables high-dynamics positioning with resolutions far below one nanometer.

Controllers and Drivers Optimized for the Application

NEXACT® actuators require special drive electronics to control the complex stepping sequences. The E-861 (see p. 1-20) includes a complete NEXACT® servo-controller with low-noise drivers and a powerful DSP. It also comes with ample software for easy integration and highly effective computer control. For applications which do not require the highest reso-

lution, the E-862 (see p. 3-10) lower-priced drive electronics, can be ordered.

The products described in this document are in part protected by the following patents:

German Patent No. P4408618.0

Linear Actuators & Motors

PiezoWalk® Motors / Actuators

PLine® Ultrasonic Motors

DC-Servo & Stepper Actuators

Piezo Actuators & Components

Guided / Preloaded Actuators

Unpackaged Stack Actuators

Patches/Benders/Tubes/Shear...

Nanopositioning / Piezoelectrics

Nanometrology

Micropositioning

Index

Technical Data (Preliminary)

Model	N-381.30	N-381.3A
Active axes	X	X
Motion and positioning		
Travel range	30 mm	30 mm
Step size (in step mode)	0.1 to 15 µm	–
Integrated sensor	–	Incremental linear encoder
Sensor resolution	–	20 nm*
Travel range in analog mode	7 µm	7 µm
Open-loop resolution	0.03 nm**	0.03 nm**
Closed-loop resolution	–	20 nm*
Step frequency	0 to 800 Hz	–
Max. velocity	10 mm/s*	10 mm/s*
Mechanical properties		
Stiffness in motion direction	2.4 N/µm	2.4 N/µm
Max. push / pull force (active)	10 N	10 N
Max. holding force (passive)	15 N	15 N
Lateral force	10 N	10 N
Drive properties		
Drive type	NEXACT® linear drive	NEXACT® linear drive
Operating voltage	-10 V to +45 V	-10 V to +45 V
Miscellaneous		
Operating temperature range	0 to 50 °C	0 to 50 °C
Material	Stainless steel / CFRP	Stainless steel / CFRP
Mass	250 g	255 g
Cable length	1.5 m	1.5 m
Connector	15-pin HD-Sub-D connector, one channel	15-pin HD-Sub-D connector, one channel
Recommended controller/driver	E-860 series (see p. 1-20)	E-861.1A1 (see p. 1-20)

*With E-861. Depending on drive electronics.

**Depending on the drive electronics. 1 nm with E-861.