

N-331 PICMAWalk Walking Drive

OEM Walking Drive for Durable Applications with up to 15 mm/s Velocity and up to 50 N Push/Pull Force



- Robust walking drive with PICMA® technology and extreme durability for industrial use
- Fastest and strongest drive of its size class
- Variable runner lengths from 25 mm to 100 mm
- Precise, nanometer precision positioning of loads up to 5 kg
- Plug-and-play, thanks to PI proprietary controller technology

PICMAWalk walking drive

The PICMAWalk walking drive combines the high reliability of the PICMA® actuators with the innovative stepping principle of the already established NEXLINE® and NEXACT® drives. Eight actuators arranged in the shape of a V ensure reliable and the highest possible feed motion with a maximum of 60 N holding force, 50 N push/pull force, and a maximum of 15 mm/s velocity.

The excellent liftoff behavior of the actuators combined with the perfectly matched flexure guides ensure extremely high durability of the drive over a travel path of 30 km, even for high-demanding continuous load in industrial applications such as alignment of large optics, detectors, and camera set-ups.

The modular design of the drives offers the possibility of implementing individual, customized requirements quickly and inexpensively. The robust PICMAWalk walking drive is a reliable and durable drive solution for nanometer precision positioning of loads up to 5 kg.

PICMA® piezo actuators

PICMA® actuators have all-ceramic insulation and their performance and lifetime are therefore far superior to conventional actuators. The ceramic insulation layer protects the monolithic piezoceramic block against humidity or failure due to increased leakage current. In this way, an especially high reliability is achieved even under extreme ambient conditions. In contrast to motorized drives, there are no rotating parts or friction. The piezo actuators are therefore free of backlash, maintenance, and wear.

Flexure guides

A flexure guide is an element free of stiction and sliding friction, which is based on the elastic deformation (bending) of a solid (e.g., steel) and does not have any rolling or sliding parts. Flexure elements have a high stiffness and load capacity. They do not wear, require no maintenance, are 100% vacuum compatible, function in a wide temperature range, and do not require any lubricants.

Fields of application

- Microscopy
- Automation technology
- Positioning loads up to 5 kg in photonics applications and permanent image inspection tasks

Related and Compatible Products

Compatible controllers / drivers / amplifiers

E-712.1AN Digital Controller for PICMAWalk Walking Drive, 1 Channel
 E-712.2AN Digital Controller for PICMAWalk Walking Drive, 2 Channels
 E-712.3AN Digital Controller for PICMAWalk Walking Drive, 3 Channels

Related products

N-111.201 NEXLINE® OEM Piezo Stepping Actuator, 10 mm, 50 N
 N-111.2A1 NEXLINE® OEM Piezo Stepping Actuator, 10 mm, 50 N, Linear Encoder, 5 nm Resolution
 N-310.10 NEXACT® OEM Linear Drive, 10 mm, 10 N
 N-310.101 NEXACT® OEM Linear Drive, 10 mm, 10 N, Offset Cable Exit
 N-310.11 NEXACT® OEM Linear Drive, 20 mm, 10 N
 N-310.111 NEXACT® OEM Linear Drive, 20 mm, 10 N, Offset Cable Exit
 N-310.12 NEXACT® OEM Linear Drive, 30 mm, 10 N
 N-310.121 NEXACT® OEM Linear Drive, 30 mm, 10 N, Offset Cable Exit
 N-310.13 NEXACT® OEM Linear Drive, 50 mm, 10 N
 N-310.131 NEXACT® OEM Linear Drive, 50 mm, 10 N, Offset Cable Exit
 N-310.14 NEXACT® OEM Linear Drive, 75 mm, 10 N
 N-310.141 NEXACT® OEM Linear Drive, 75 mm, 10 N, Offset Cable Exit
 N-310.15 NEXACT® OEM Linear Drive, 100 mm, 10 N
 N-310.151 NEXACT® OEM Linear Drive, 100 mm, 10 N, Offset Cable Exit
 N-310.16 NEXACT® OEM Linear Drive, 125 mm, 10 N
 N-310.161 NEXACT® OEM Linear Drive, 125 mm, 10 N, Offset Cable Exit

Specifications

	N-331.10 / N-331.13 N-331.20 / N-331.23 N-331.40 / N-331.43	Unit	Tolerance
Active axes	X		
Motion and positioning			
Integrated sensor	N-331.x0: Without sensor N-331.x3: With incremental sensor		
Travel range (step mode, open loop)*	N-331.1x: 30 N-331.2x: 55 N-331.4x: 105	mm	±0.5 mm
Travel range (step mode, closed loop)	N-331.1x: 25 N-331.2x: 50 N-331.4x: 100	mm	

Step size	10 nm to 25 μm		typ.
Step frequency**	600	Hz	max.
Velocity (step mode)**	15	mm/s	max.
Travel range (analog mode)	± 10	μm	typ.
Resolution (open loop)	0.02	nm	typ.
Resolution (closed loop)	<10 (N-331.x3)	nm	typ.
Endurance (atmospherical operation)***	>30	km	
Mechanical properties			
Stiffness in motion direction	6	N/ μm	$\pm 20\%$
Push/pull force (active)	50	N	max.
Holding force (passive)	60	N	max.
Drive properties			
Drive type	PICMAWalk		
Operating voltage	-20 to 120	V	
Connectors			
Connector	Sub-D 37-pin (m)		
Miscellaneous			
Operating temperature range	-20 to 50	$^{\circ}\text{C}$	
Material	Aluminum, stainless steel		
Mass with cable	N-331.1x: 580 N-331.2x: 610 N-331.4x: 660	g	
Moved Mass	N-331.1x: 110 N-331.2x: 140 N-331.4x: 190	g	$\pm 10\text{ g}$
Cable length	2.0	m	$\pm 10\text{ mm}$
Recommended controllers / amplifiers	E-712.1AN E-712.2AN E-712.3AN		

Ask about custom designs!

* From one mechanical hard stop of the runner to the other mechanical hard stop, only in open-loop operation

** When operating with the E-712.xAN

*** At a load of 2 kg with max. 70 % duty cycle and external cooling of the E-712.1AN, at 20 $^{\circ}\text{C}$ and 1013 hPa

Drawings and Images

Dimensions in mm. Note that the decimal places are separated by a comma in the drawings.
 Drive dimensions without runner: 55 mm × 55 mm × 31 mm

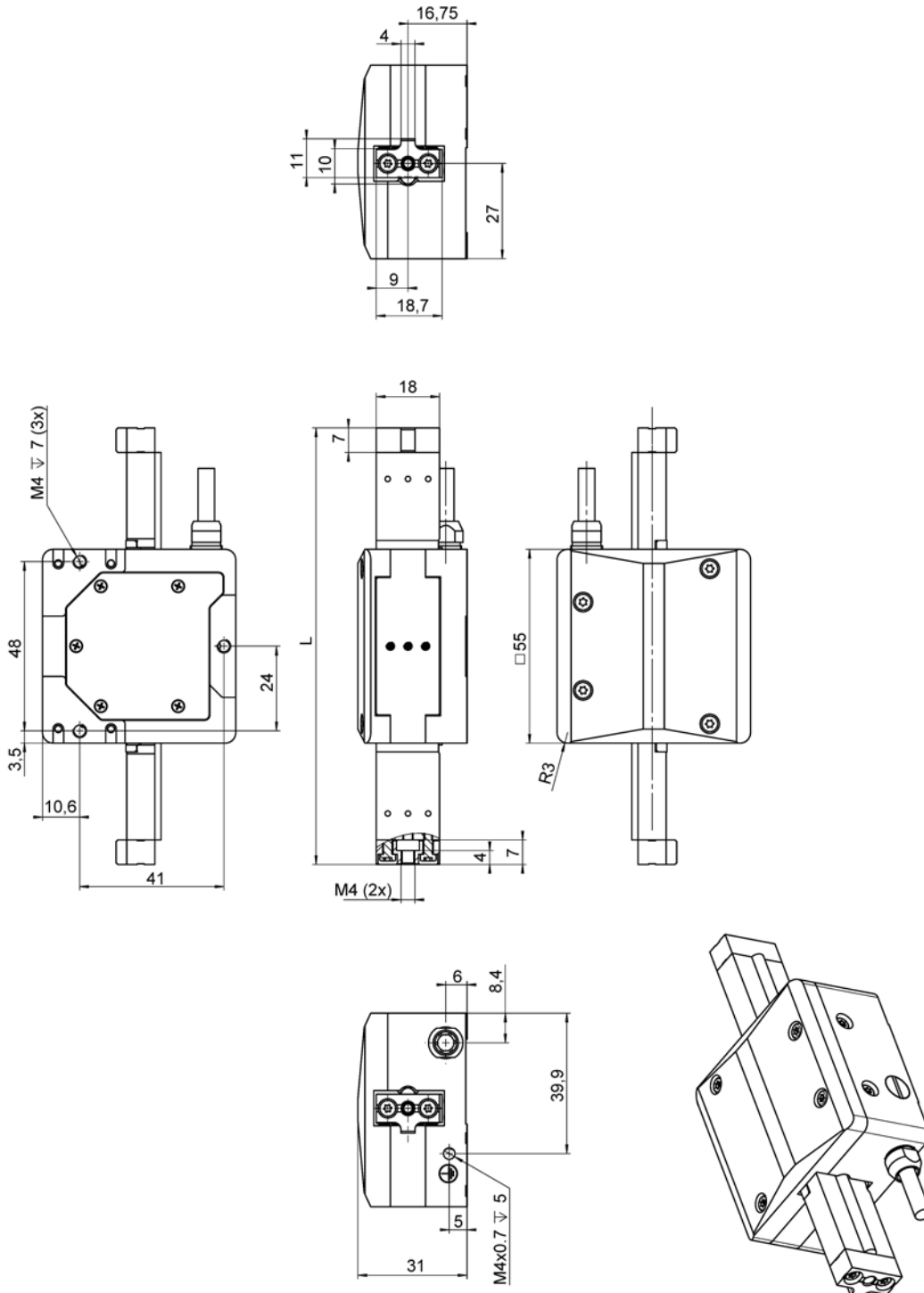

N-331.x3, dimensions for the N-331.x0 are identical

N-331.1x: L = 99 mm

N-331.2x: L = 124 mm

N-331.4x: L = 174 mm

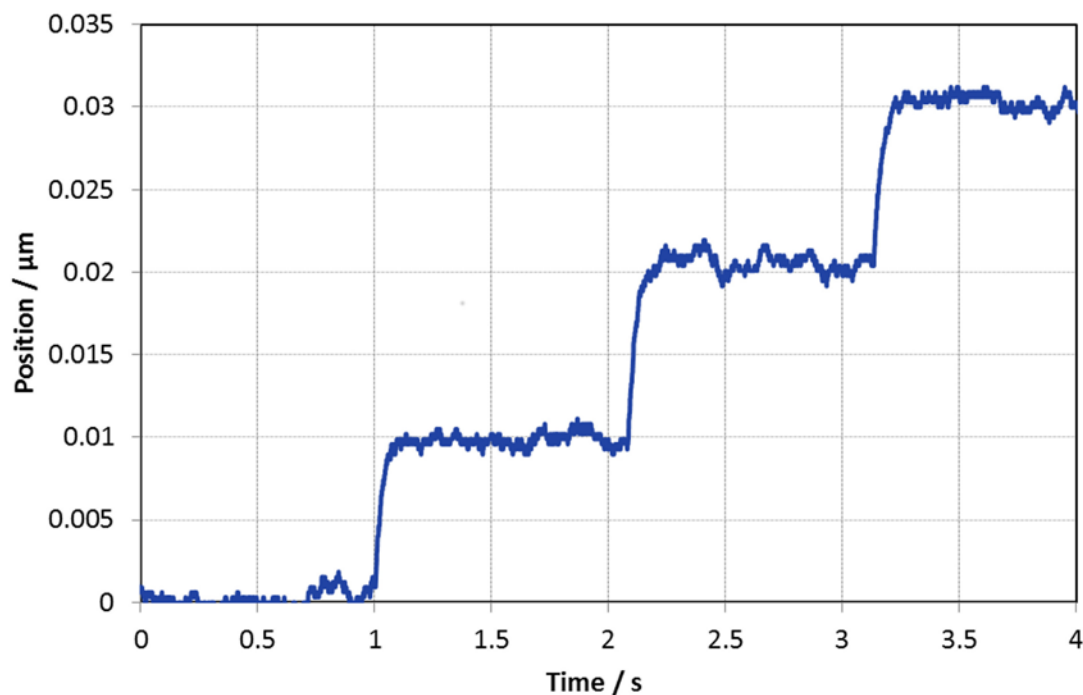

The N-331 drive reliably performs repeatable 10-nm steps. An interferometer was used for measuring

Ordering Information

N-331.10

Piezoelectric Walking Drive PICMAWalk, 25 mm Travel Range, Open Loop, 50 N Push/Pull Force

N-331.13

Piezoelectric Walking Drive PICMAWalk, 25 mm Travel Range, Incremental Sensor, 50 N Push/Pull Force

N-331.20

Piezoelectric Walking Drive PICMAWalk, 50 mm Travel Range, Open Loop, 50 N Push/Pull Force

N-331.23

Piezoelectric Walking Drive PICMAWalk, 50 mm Travel Range, Incremental Sensor, 50 N Push/Pull Force

N-331.40

Piezoelectric Walking Drive PICMAWalk, 100 mm Travel Range, Open Loop, 50 N Push/Pull Force

N-331.43

Piezoelectric Walking Drive PICMAWalk, 100 mm Travel Range, Incremental Sensor, 50 N Push/Pull Force

Ask about custom designs!