

F-130 · F-131 Compact XYZ Motorized Fiber Positoner

DC/Piezo Drive System for Nanometer Precision, Photonics Automated Alignment



F-130.3SD XYZ Alignment System,
1 nm resolution, with optional F-603.22 ferrule holder

- Up to 15 mm Travel
- 1 nm Resolution
- Closed-Loop Piezo Drives Available
- Stepper- & DC-Motor Drives

F-130 are compact computer-controllable XYZ alignment and positioning systems combining the advantages of ultra-high-resolution piezo drives with the long travel range of motorized stages.

They are based on the M-110/ M-111 micropositioning stages (see page 4-22) and the P-611

Application Examples

- Photonics packaging
- Optical device testing
- MEMS positioning/alignment
- Fiber alignment
- Micromachining
- Micromanipulation (life sciences)
- Semiconductor test systems

rapid piezo NanoAlignment units (see page 2-20).

The F-130/F-131 is available in 8 different versions, with stepper- and DC-motor coarse drives, and open- and closed-loop piezoelectric fine drives. (see Ordering Information).

The motor drives provide better than 0.05 μm resolution over a travel range of 5 and 15 mm. The piezo fine drives feature a 100 μm travel range in X, Y and Z, with zero-stiction, zero-friction flexure guiding systems and 1 nm resolution.

Several fiber, waveguide and optics adapters are available from PI (e.g. model F-603.60, see "Fiber, Objective and Waveguide Holders").

The C-880 multi-axis automation platform (see page 4-124) is recommended as controller.

Ordering Information

F-130.3SD
XYZ Alignment System, 5 mm / 100 μm , DC Motor/Encoder, C/L Piezo

F-130.3SS
XYZ Alignment System, 5 mm / 100 μm , Stepper Motor, C/L Piezo

F-130.3OD
XYZ Alignment System 5 mm / 100 μm , DC Motor/Encoder, O/L Piezo

F-130.3OS
XYZ Alignment System, 5 mm / 100 μm , Stepper Motor, O/L Piezo

F-131.3SD
XYZ Alignment System, 15 mm / 100 μm , DC Motor/Encoder, C/L Piezo

F-131.3SS
XYZ Alignment System, 15 mm / 100 μm , Stepper Motor, C/L Piezo

F-131.3OD
XYZ Alignment System, 15 mm / 100 μm , DC Motor/Encoder, O/L Piezo

F-131.3OS
XYZ Alignment System, 15 mm / 100 μm , Stepper Motor, O/L Piezo

Ask about custom designs!

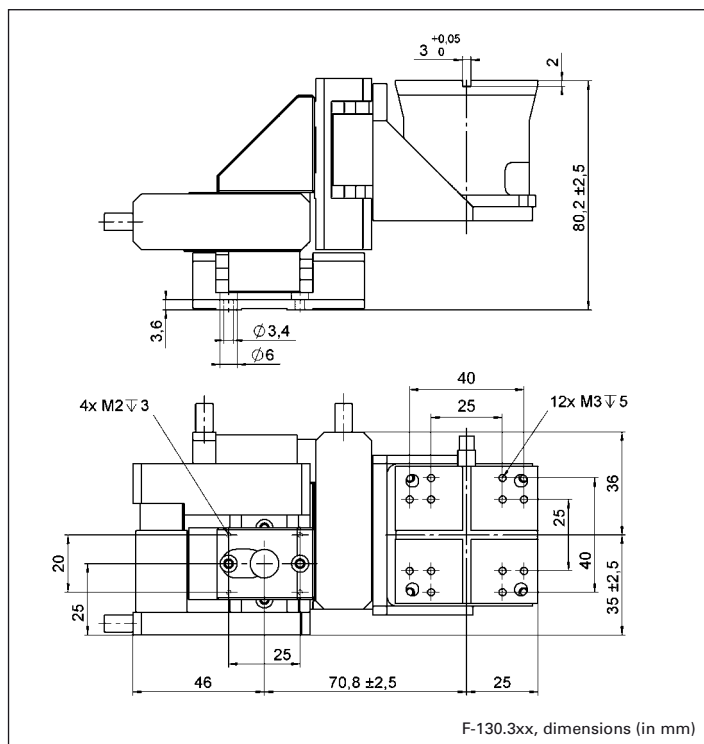



The C-880 Multi-axis automation platform is recommended as controller for the F-130/F-131

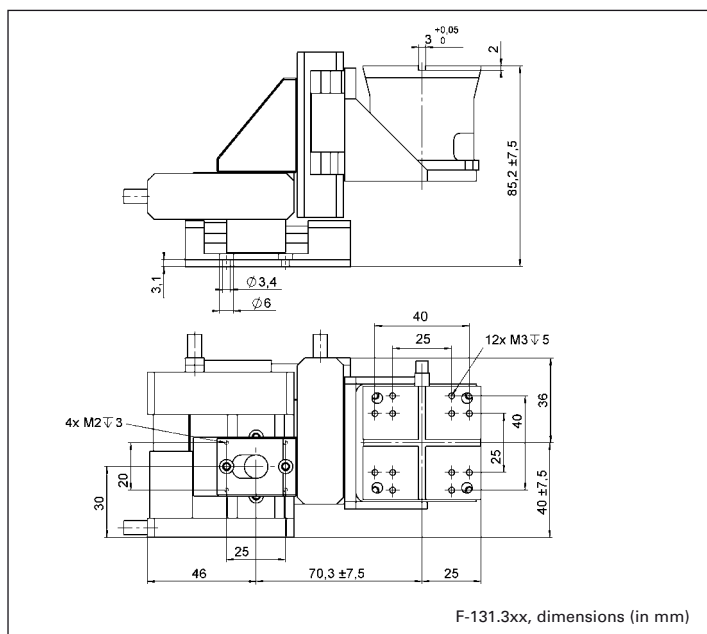

Technical Data

Model	F-130.3SD	F-130.3SS	F-130.3OD	F-130.3OS	F-131.3SD	F-131.3SS	F-131.3OD	F-131.3OS	Units
Key features	Closed-loop DC motors, closed-loop PZT drives	Stepper motors, closed-loop PZT drives	Closed-loop DC motors, open-loop PZT drives	Stepper motors, open-loop PZT drives	Closed-loop DC motors, closed-loop PZT drives	Stepper motors, closed-loop PZT drives	Closed-loop DC motors, open-loop PZT drives	Stepper motors, open-loop PZT drives	
Active axes	X,Y,Z	X,Y,Z	X,Y,Z	X,Y,Z	X,Y,Z	X,Y,Z	X,Y,Z	X,Y,Z	
Motorized travel range (XYZ)	5	5	5	5	15	15	15	15	mm
Piezo travel range (XYZ)	100	100	100	100	100	100	100	100	µm
Design resolution (motor)	0.007	0.006	0.007	0.006	0.007	0.006	0.007	0.006	µm
Min. incremental motion (motor)	0.05	0.05	0.05	0.05	0.05	0.05	0.05	0.05	µm
Closed-loop / open-loop resolution (PZT)	2/1	2/1	- / 1	- / 1	2/1	2/1	- / 1	- / 1	nm
Motorized stage	M-110.3DG	M-110.32S	M-110.3DG	M-110.32S	M-111.3DG	M-111.32S	M-111.3DG	M-111.32S	
Piezo drive	P-611.3SF	P-611.3SF	P-611.3OF	P-611.3OF	P-611.3SF	P-611.3SF	P-611.3OF	P-611.3OF	
Material	Al / S	Al / S	Al / S	Al / S	Al / S	Al / S	Al / S	Al / S	
Recommended controller	C-880	-	C-880	-	C-880	-	C-880	-	