

D-510 PISeca Capacitive Sensors

Single-Plate Sensors with Excellent Position Resolution



PISeca high-precision capacitive sensor probes with E-852 signal conditioner electronics. Sensor probes (from left): D-510.101 with 100 μm , D-510.051 with 50 μm , D-510.021 with 20 μm nominal measurement range

- **Non-Contact Measurement for Distance / Motion / Vibration**
- **Absolute Position Sensing**
- **Sub-Nanometer Resolution**
- **Measurement Ranges to 500 μm**
- **Easy Integration**
- **High Bandwidth**

The new PISeca single-electrode capacitive sensors from PI perform non-contact measurements of distance, position or motion against any kind of electrically conductive target. They feature the highest resolution and linearity available.

The PISeca single-electrode capacitive gauges are fundamentally very temperature stable, have excellent dynamics and are easy to work with.

Application Examples

- Semiconductor technology / test & measurement
- Data storage
- Automotive industry
- Metrology
- Precision machining

Capacitive Position Sensors for Highest Accuracy and Lifetime

Single-electrode capacitive (capacitance) sensors are direct metrology devices. They use an electric field to measure change of capacitance between the probe and a conductive target surface, without physical contact. This makes them free of fric-



D-510.021 with LEMO connector for easy handling

tion and hysteresis and provides high phase fidelity and bandwidth.

In combination with suitable sensor electronics (E-852.10) resolutions down to the sub-nanometer range and bandwidths to 10 kHz can be achieved. For high-dynamics measurements, a bandwidth up to 10 kHz is possible, with a resolution still down to the 1-nm range. With sufficient mounting accuracy, excellent linearity can be attained (up to 0.1%).

Guard-Ring Capacitor Provides Higher Linearity

Sensor design has a strong influence on linearity because the operating principle is based on that of an ideal parallel-plate capacitor. The superior PI design uses a guard-ring electrode that shields the sensor electrode from boundary effects. This ensures a homogeneous electric field in the measurement zone and results in higher measuring linearity.

Easy Handling and Integration

All PISeca sensor probes feature an integrated LEMO connector for easy mounting and replacement in the field. The standardized shaft diameter allows compatibility and flexibility.

Factory Calibration for Improved Linearity

Highest possible linearity and accuracy are achieved with factory calibration of the sensor probe together with the signal conditioner electronics. Two measurement ranges can be calibrated at the same time for one particular sensor probe. Factory calibration also optimizes parameters like ILS (linearization), gain and offset and eliminates cable capacitance influences. The E-852.10 provides two calibrated, optionally

Ordering Information

D-510.021
PISeca, Single-Electrode Capacitive Sensor Probe, 8 mm Diameter, 20 μm Nominal Range

D-510.051
PISeca, Single-Electrode Capacitive Sensor Probe, 12 mm Diameter, 50 μm Nominal Range

D-510.101
PISeca, Single-Electrode Capacitive Sensor Probe, 20 mm Diameter, 100 μm Nominal Range

Accessories

D-891.01E
Sensor Cable PISeca, 1 m

D-891.02E
Sensor Cable PISeca, 2 m

D-891.01A
Sensor Cable PISeca, Right-Angle Connector, 1 m

D-891.02A
Sensor Cable PISeca, Right-Angle Connector, 2 m

Other cable lengths available on request.

Ask about custom designs!

extended measurement ranges are available.

High-Precision Machining

The measuring surfaces of the PISeca sensors are machined with diamond tools using sophisticated process control techniques. The result is the smooth, ultra-flat, mirrored surface required to obtain highest resolution. The standard material is stainless steel.

Custom Sensors / Two-Plate Sensors

In addition to the standard sensors listed here, PI can offer a variety of custom versions for different measuring ranges, geometries, materials match, etc. Systems with custom electronics are also available.

If ultimate performance is required, the D-100 series two-plate capacitive sensors are recommended (see p. 3-14 ff).

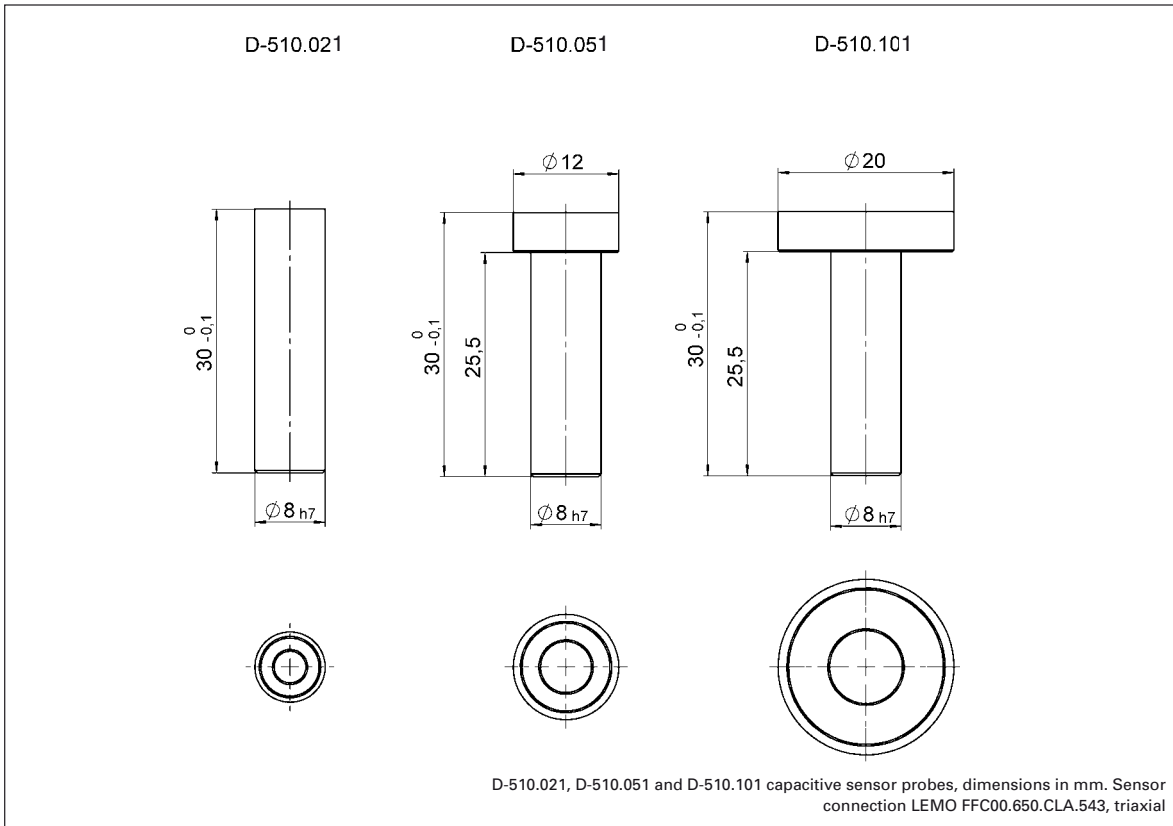
Linear Actuators & Motors

Nanopositioning / Piezoelectrics

Nanometrology

**Capacitive Sensors /
Signal Conditioners**

Nanometrology Fundamentals

Micropositioning

Index

Technical Data

| Model | D-510.021 | D-510.051 | D-510.101 | Units | Tolerance |
|--|------------------------------|------------------------------|---|------------------------|-----------|
| Sensor type | Single-electrode, capacitive | Single-electrode, capacitive | Single-electrode, capacitive | | |
| Measurement accuracy | | | | | |
| Nominal measurement range* | 20 | 50 | 100 | µm | |
| Min. gap | 10 | 25 | 50 | µm | |
| Max. gap | 150 | 375 | 750 | µm | |
| Static resolution** | <0.001 | <0.001 | <0.001 | % of measurement range | typical |
| Dynamic resolution** | <0.002 | <0.002 | <0.002 | % of measurement range | typical |
| Linearity*** | <0.2 | <0.1 | <0.1 | % | |
| Mechanical properties | | | | | |
| Sensor active diameter | 3.8 | 6 | 8.4 | mm | |
| Sensor active area | 11.2 | 27.9 | 56.1 | mm ² | |
| Sensor diameter | 8 | 12 | 20 | mm | |
| Sensor area | 50.3 | 113.1 | 314.0 | mm ² | |
| Mounting shaft diameter | 8 | 8 | 8 | mm | |
| Miscellaneous | | | | | |
| Operating temperature range | -20 to +100 | -20 to +100 | -20 to +100 | °C | |
| Material | Stainless steel | Stainless steel | Stainless steel | | |
| Mass | 8 | 10 | 16 | g | ±5 % |
| Recommended signal conditioner electronics | E-852.10 E-509.E | E-852.10 E-509.E | E-852.10 (p. 3-10) E-509.E (p. 3-12) | | |

*Extended measurement ranges available for calibration with E-852 signal conditioner electronics

**Static resolution: bandwidth 10 Hz, dynamic: bandwidth 10 kHz, with E-852.10 signal conditioner electronics

***Linearity over nominal measurement range