

# P-517 · P-527 Multi-Axis Piezo Scanner

## High-Dynamics Nanoscanner for Scanning Probe Microscopy



P-527.2CL parallel-kinematic nanopositioning system

- Travel Ranges to 200  $\mu\text{m}$
- Sub-Nanometer Resolution
- Frictionless, High-Precision Flexure Guiding System
- Capacitive Sensors for Highest Linearity
- Parallel-Kinematics / Metrology for Enhanced Responsiveness / Multi-Axis Precision
- Clear Aperture 66 x 66 mm
- Outstanding Lifetime Due to PICMA® Piezo Actuators

P-517 and P-527 high-dynamics, multi-axis piezo-nanopositioning stages are available in XY  $\Theta$ Z, XY and XYZ configurations featuring linear travel ranges to 200 x 200 x 20  $\mu\text{m}$  and rotation ranges to 4 mrad. The 66 x 66 mm clear aperture is ideal for transmitted-light applications.

Z/tip/tilt versions in the same form factor are also offered as models P-518, P-528, P-558 (see p. 2-46) and as custom versions with up to six degrees of freedom.

### Capacitive Sensors for Highest Accuracy

PI's proprietary capacitive sensors measure position directly and without physical contact. They are free of friction and hysteresis, a fact which, in combination with the positioning

### Application Examples

- Metrology
- Interferometry
- Optics
- Lithography
- Nanopositioning
- Scanning microscopy
- Mass storage device testing
- Laser technology
- Micromachining

resolution of well under 1 nm, makes it possible to achieve very high levels of linearity. A further advantage of direct metrology with capacitive sensors is the high phase fidelity and the high bandwidth of up to 10 kHz.

### Technical Data

Model	P-517.2CL	P-527.2CL	P-517.3CL/ P-517.3CD	P-527.3CL/ P-527.3CD	P-517.RCD	P-527.RCD
Active axes	X, Y	X, Y	X, Y, Z	X, Y, Z	X, Y, $\theta_z$	X, Y, $\theta_z$
<b>Motion and positioning</b>						
Integrated sensor	Capacitive	Capacitive	Capacitive	Capacitive	Capacitive	Capacitive
Open-loop travel, -20 to +120 V	130	250	130; Z: 25	250; Z: 25	130; $\theta_z$ : $\pm 1.3$ mrad	250; $\theta_z$ : $\pm 2.5$ mrad
Closed-loop travel	100	200	100; Z: 20	200; Z: 20	100; $\theta_z$ : $\pm 1$ mrad	200; $\theta_z$ : $\pm 2$ mrad
Open-loop resolution	0.3	0.5	0.3; Z: 0.1	0.5; Z: 0.1	0.3; $\theta_z$ : $\pm 0.1$ $\mu\text{rad}$	0.5; $\theta_z$ : $\pm 0.1$ $\mu\text{rad}$
Closed-loop resolution	1	2	1; Z: 0.1	2; Z: 0.1	1; $\theta_z$ : $\pm 0.3$ $\mu\text{rad}$	2; $\theta_z$ : $\pm 0.3$ $\mu\text{rad}$
Linearity	0.03	0.03	0.03	0.03	0.03	0.03
Repeatability	$\pm 5$	$\pm 10$	$\pm 5$ ; Z: $\pm 1$	$\pm 10$ ; Z: $\pm 1$	$\pm 5$ ; $\theta_z$ : $\pm 0.5$ $\mu\text{rad}$	$\pm 10$ ; $\theta_z$ : $\pm 1$ $\mu\text{rad}$
<b>Mechanical properties</b>						
Stiffness	2	1	2; Z: 15	1; Z: 15	2	1
Unloaded resonant frequency	450	350	450; Z: 1100	350; Z: 1100	450; $\theta_z$ : 400	350; $\theta_z$ : 300
Resonant frequency @ 500 g X, Y	250	190	250	190	250	190
Resonant frequency @ 2500 g X, Y	140	110	140	110	140	110
Push/pull force capacity in motion direction	50 / 30	50 / 30	50 / 30	50 / 30	50 / 30	50 / 30
<b>Drive properties</b>						
Ceramic type	PICMA® P-885	PICMA® P-885	PICMA® P-885	PICMA® P-885	PICMA® P-885	PICMA® P-885
Electrical capacitance	9.2	9.2	9; Z: 6	9; Z: 6	9	9
Dynamic operating current coefficient (DOCC)	11.5	5.8	11.5; Z: 37	5.5; Z: 37	11.5	5.5
<b>Miscellaneous</b>						
Operating temperature range	-20 to 80	-20 to 80	-20 to 80	-20 to 80	-20 to 80	-20 to 80
Material	Aluminum	Aluminum	Aluminum	Aluminum	Aluminum	Aluminum
Mass	1.4	1.4	1.45	1.45	1.4	1.4
Sensor / voltage connection	LEMO	LEMO	Sub-D special (CD-version) LEMO (CL-version)	Sub-D special (CD-version) LEMO (CL-version)	Sub-D Special	Sub-D Special

Resolution of PI Piezo Nanopositioners is not limited by friction or stiction. Value given is noise equivalent motion with E-503 or E-710 controller (p. 2-146 or p. 2-128)

Linear Dynamic Operating Current Coefficient in  $\mu\text{A}$  per Hz and  $\mu\text{m}$ . Example for P-527.2xx: Sinusoidal scan of 30  $\mu\text{m}$  at 10 Hz requires approximately 1.8 mA drive current (p. 2-70). Electrical capacitance and DOCC of the rotation axes base upon differential motion in X, Y, therefore not stated.

Recommended controller

Versions with LEMO connectors: Single-channel (1 per axis): E-610 servo-controller / amplifier (p. 2-110), E-625 servo-controller, bench-top (p. 2-114), E-621 controller module (p. 2-160) Multi-channel: modular piezo controller system E-500 (p. 2-142) with amplifier module E-503 (three channels) (p. 2-146) or E-505 (1 per axis, high-power) (p. 2-147) and E-509 controller (p. 2-152)

Versions with Sub-D connectors: Multi-channel digital controllers: E-710 bench-top (p. 2-128), E-712 modular (p. 2-140), E-725 high-power (p. 2-126), E-761 PCI board (p. 2-130)

### Active and Passive Guidance for Nanometer Flatness and Straightness

Flexures optimized with Finite Element Analysis (FEA) are used to guide the stage. The FEA techniques provide for the highest possible stiffness in, and perpendicular to, the direction of motion, and minimize linear and angular runout. Flexures allow extremely high-precision motion, no matter how minute, as they are completely free of play and friction. Due to the parallel kinematics design there is only one common moving platform for all axes, minimizing mass, enabling identical dynamic behavior and eliminating cumulative errors. Parallel kinematics also allows for a more compact construction and faster response compared

to stacked or nested designs. The high precision due to flexure guidance is further enhanced by Active Trajectory Control: Multi-axis nanopositioning systems equipped with both parallel kinematics and parallel direct metrology are able to measure platform position in all degrees of freedom against one common fixed reference. In such systems, undesirable motion from one actuator in the direction of another (cross-talk) is detected immediately and actively compensated by the servo-loops. This Active Trajectory Control Concept can keep deviation from a trajectory to under a few nanometers, even in dynamic operation.

### Ceramic Insulated Piezo Actuators Provide Long Lifetime

Highest possible reliability is assured by the use of award-winning PICMA® multilayer piezo actuators. PICMA® actuators are the only actuators on the market with ceramic-only insulation, which makes them resistant to ambient humidity and leakage-current failures. They are thus far superior to conventional actuators in reliability and lifetime.

### Ordering Information

#### P-517.2CL

Precision XY Nanopositioning System, 100 x 100  $\mu\text{m}$ , Capacitive Sensors, Parallel Metrology, LEMO Connector

#### P-527.2CL

Precision XY Nanopositioning System, 200 x 200  $\mu\text{m}$ , Capacitive Sensors, Parallel Metrology, LEMO Connector

#### P-517.3CL

Precision XYZ Nanopositioning System, 100 x 100 x 20  $\mu\text{m}$ , Capacitive Sensors, Parallel Metrology, LEMO Connector

#### P-517.3CD

Precision XYZ Nanopositioning System, 100 x 100 x 20  $\mu\text{m}$ , Capacitive Sensors, Parallel Metrology, Sub-D Connector

#### P-527.2CL

Precision XY Nanopositioning System, 200 x 200  $\mu\text{m}$ , Capacitive Sensors, Parallel Metrology, LEMO Connector

#### P-527.3CD

Precision XYZ Nanopositioning System, 200 x 200 x 20  $\mu\text{m}$ , Capacitive Sensors, Parallel Metrology, Sub-D Connector

#### P-517.RCD

Precision XY / Rotation Nanopositioning System, 100 x 100  $\mu\text{m}$ , 2 mrad, Capacitive Sensors, Parallel Metrology, Sub-D Connector

#### P-527.RCD

Precision XY / Rotation Nanopositioning System, 200 x 200  $\mu\text{m}$ , 4 mrad, Capacitive Sensors, Parallel Metrology, Sub-D Connector

Linear Actuators & Motors

Nanopositioning/Piezoelectrics

Piezo Flexure Stages / High-Speed Scanning Systems

Linear

Vertical & Tip/Tilt

2- and 3-Axis

6-Axis

Fast Steering Mirrors / Active Optics

Piezo Drivers / Servo Controllers

Single-Channel

Multi-Channel

Modular

Accessories

Piezoelectrics in Positioning

Nanometrology

Micropositioning

Index

Units	Tolerance
$\mu\text{m}$	min.(+20%/0%)
nm	typ.
%	typ.
N	typ.
N/ $\mu\text{m}$	$\pm 20\%$
Hz	$\pm 20\%$
Hz	$\pm 20\%$
Hz	$\pm 20\%$
N	Max.
$\mu\text{F}$	$\pm 20\%$
$\mu\text{A}/(\text{Hz} \cdot \mu\text{m})$	$\pm 20\%$
$^{\circ}\text{C}$	
kg	$\pm 5\%$

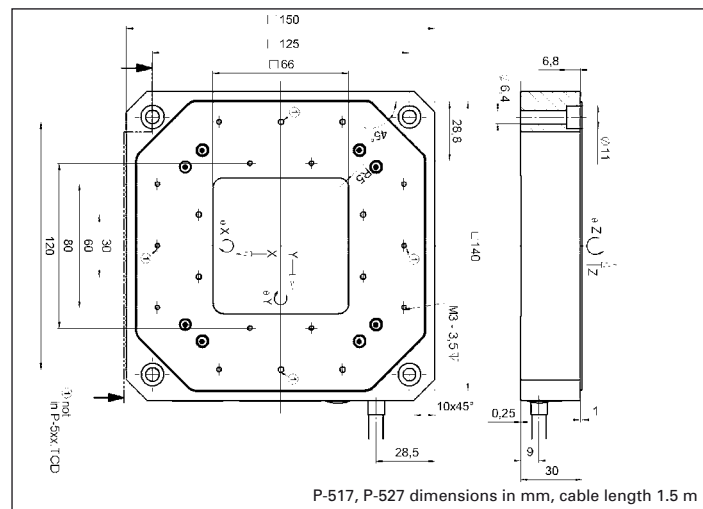

P-517, P-527 dimensions in mm, cable length 1.5 m