



PILine[®] Ultrasonic Piezomotors

SMALL, HIGH-SPEED AND COST-EFFICIENT

PILine®

FROM OEM DRIVES TO MULTI-AXIS POSITIONING SYSTEMS

Nanopositioning with piezomotors over long travel ranges

Piezomotors are optimally suited for using the specific properties of piezo actuators to achieve longer travel ranges. Adapted to the required force and velocity development, PI provides a series of different piezomotor technologies, each of which focuses on different features. For example, PI piezomotors that feature high stiffness and resolutions in the nanometer range are used for nanometer-precision stages with travel ranges over 1 mm.

Piezomotor properties

- Self-locking when powered off with maximum holding force
- Piezomotors do not generate magnetic fields nor are they affected by them
- Scalable travel ranges
- Nanometer-precision resolution
- Easy mechanical integration
- Different technologies optimized for high velocities or for high forces

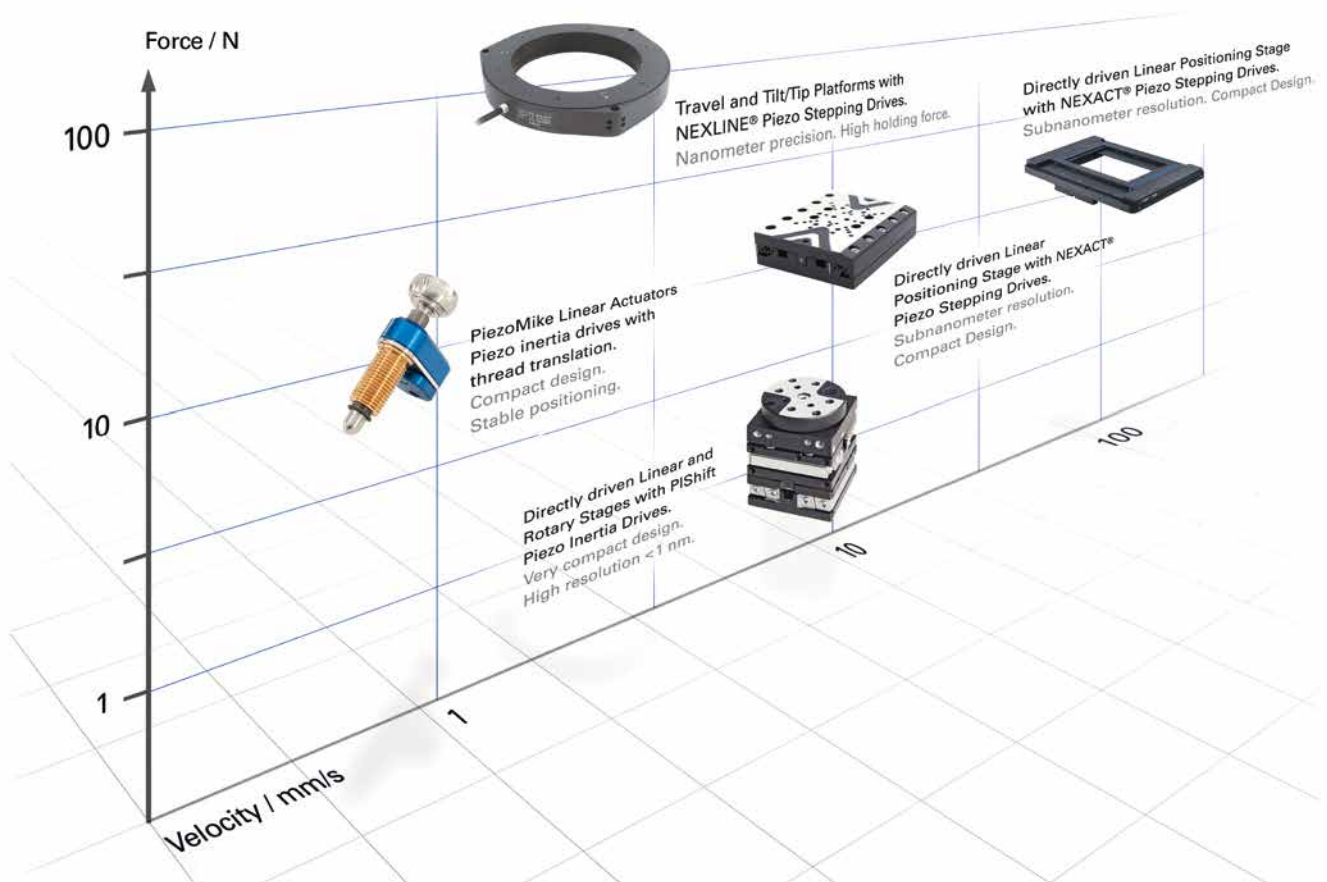

Ultrasonic Piezomotors

INTEGRATION EXAMPLES OF PIEZO LINEAR MOTORS

Motor-lead screw combinations transform the rotational motion of the motor into linear motion. Due to play in the mechanical components responsiveness is limited. Linear motors such as PILine® generate linear motion directly and provide much faster response and better stability. Furthermore, they allow significantly smaller designs.

PiezoWalk® Drives like NEXLINE® and NEXACT® offer nanometer resolution with the highest force at low velocities and are intended for low duty cycles. PILine® ultrasonic drives provide fast feeds and a positioning accuracy in the sub-micrometer range. PIShift drives use only a

single piezo actuator and benefit from a simple drive principle, allowing for nanometer-precision positioning.

All piezomotor drives, independent from the technology used, are self-locking when powered off. This is due to their design where the piezoactuator is preloaded orthogonally to the direction of motion. Thus, piezomotors are ideal for precise and stable positioning even over a long standstill.



M-663 PILine® miniature stage



M-110 compact translation stage with motor and lead screw

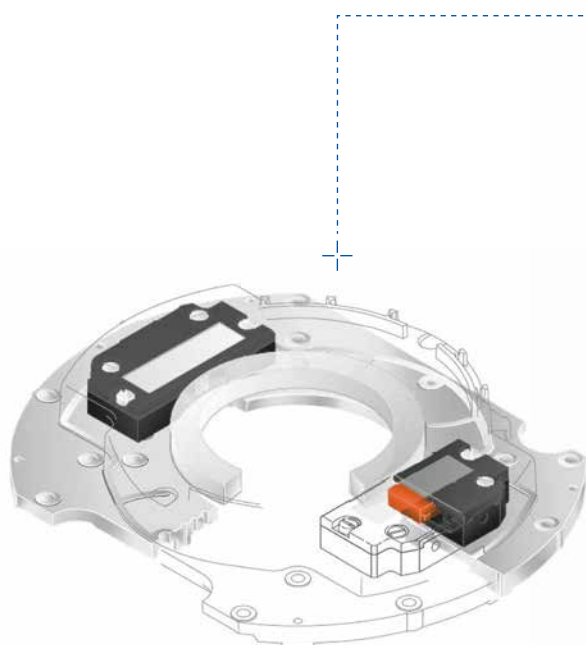

PILine® motors act on an annular runner, producing a rapid rotary motion, e.g. for this Leica TS30 total station for automated angle and distance measurement at high accuracy and reliability (Image: Leica Geosystems)

PILine® Ultrasonic Piezomotors

SMALL, HIGH-SPEED AND COST-EFFICIENT



- Silent operation through control frequencies in the ultrasonic range
- Cost-efficient drive principle: One actuator, one control phase
- Easy mechanical integration, compact design
- Self-locking at rest: No holding currents, no heating at stop, no energy consumption and no control jitter
- Holding force up to 15 N
- Velocity to 500 mm/s
- Resolution to 1 nm

Applications

PILine® ultrasonic piezomotors are small, high-speed and cost-efficient. Ideally suitable for applications of low operating cycles, they can also be integrated as drive into mobile measuring and medical devices. Due

to their self-locking, the target position does not have to be held via additional brakes or electrical currents as in the case of magnetic drives.

PILine® Linear Positioning Stages



U-521

Compact Linear Stage

Fast PLine® Direct Drive, Incremental Encoder

PILine® Rotation Stages



U-622

Miniature Rotation Stage

20 mm Side Length, Integrated Encoder

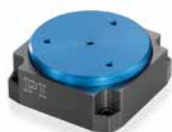

U-624

Fast Miniature Rotation Stage

With Ultrasonic Piezomotor



U-628

Fast Rotation Stage with Small Footprint

With Ultrasonic Piezomotor



U-651

Rotation Stage with Low-Profile Design

Fast PLine® Direct Drive

Motion Control



C-877

PILine® Motion Controller

For Ultrasonic Piezomotors, Cost-Efficient and Compact



C-867U

PILine® Motion Controller

For Ultrasonic Piezomotors, 1 and 2 Axes

Compact Linear Stage

FAST PILINE® DIRECT DRIVE, INCREMENTAL ENCODER



U-521

- Only 35 mm wide and 10 mm high
- Integrated, direct-measuring incremental encoder with up to 100 nm resolution
- Up to 0.3 μm minimum incremental motion
- Travel range 18 mm
- Velocity 200 mm/s
- Feed force 2 N
- Versions vacuum-compatible to 10^{-6} hPa

Precision-class micropositioning stage

Piezoelectric ultrasonic direct drive for high velocities and small design. Centered ball bearings. The piezomotor drive principle and the electrical operation are cost-efficient and can be customized

Direct-measuring principle

Integrated, direct-measuring incremental encoder. Resolution depending on version, 400 nm or 100 nm. Optical reference point switch

PILine® ultrasonic piezo motor

Oscillating piezoceramic actuators act directly on a linear-

guided runner. Self-locking at rest, therefore no heat generation. No drive noises. High velocity up to 200 mm/s. Dynamic start / stop behavior. Holding force 2 N.

Valid patents

US patent no. 6,765,335B2

European patent no. 1267425B1

Fields of application

Industry and research. For micromanipulation, automation, biotechnology, sample manipulation, sample positioning. Use in limited space. Vacuum version for 10^{-6} hPa optional

Preliminary Data	U-521.23; U-521.23V	U-521.24; U-521.24V	Unit	Tolerance
	Linear stage with 0.4 μm sensor resolution U-521.23V for vacuum to 10^{-6} hPa	Linear stage with 0.1 μm sensor resolution U-521.24V for vacuum to 10^{-6} hPa		
Active axes	X	X		
Motion and Positioning				
Travel Range	18	18	mm	
Integrated sensor	Incremental encoder	Incremental encoder		
Design resolution	0.4	0.1	μm	typ.
Minimum incremental motion	2	0.3	μm	typ.
Bidirectional repeatability	± 2	± 0.5	μm	
Velocity	200	200	mm/s	max.
Mechanical Properties				
Load capacity	2	2	N	max.
Holding force	2	2	N	max.
Drive force	2	2	N	max.
Drive Properties				
Motor Type	PILine® ultrasonic piezomotor, performance class 1	PILine® ultrasonic piezomotor, performance class 1		
Reference point switch	Optical	Optical		
Miscellaneous				
Operating temperature range	0 to 40	0 to 40	$^{\circ}\text{C}$	
Material	Aluminum, anodized	Aluminum, anodized		
Mass	150	150	g	$\pm 5\%$
Cable length	1.5	1.5	m	± 10 mm
Connector	Sub-D 15-pin (m)	Sub-D 15-pin (m)		
Recommended controller/driver	C-867.1U: 1 channel C-867.2U: 2 channels C-877.1U11: 1 channel, affordable compact device C-877.2U12: 2 channels, affordable bench-top	C-867.1U: 1 channel C-867.2U: 2 channels C-877.1U11: 1 channel, affordable compact device C-877.2U12: 2 channels, affordable bench-top		

Ask about custom designs!
The U-521 stage series replace the M-663 series

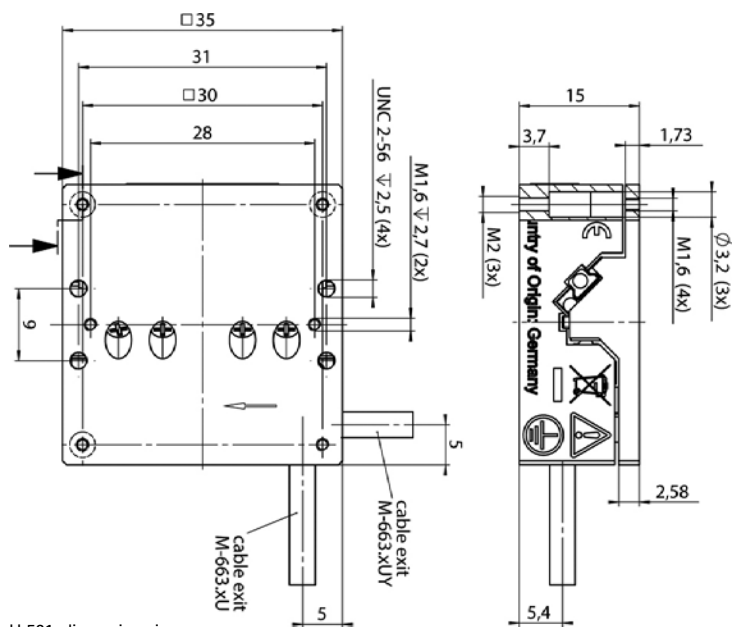

U-521, dimensions in mm

Miniaturized Rotation Stage

20 MM SIDE LENGTH, INTEGRATED ENCODER



U-622

- Only 20 mm edge length, height 10 mm
- Integrated, direct-measuring incremental encoder
- Rotation range $>360^\circ$
- High velocity 720 $^\circ/\text{s}$
- Drive torque 5 mNm

Precision-class miniature rotation stage

Integrated, direct-measuring incremental encoder.
Rotation range $>360^\circ$. Optical reference point switch

PILine® ultrasonic piezo motor

The piezoceramic ring-shaped motor acts directly on the rotating platform. Self-locking at rest, therefore no heat

generation. No drive noises. High velocity to 720 $^\circ/\text{s}$. Holding torque 5 mNm

Fields of application

Sample handling and positioning in research and industry for installations limited in space. Vacuum version for 10^{-6} hPa optional

	U-622.03	Unit	Tolerance
Active axes	θ_z		
Motion and Positioning			
Rotation range	>360	°	
Integrated sensor	Incremental encoder		
Design resolution	175	μrad	
Min. incremental motion	525	μrad	typ.
Bidirectional repeatability	± 1050	μrad	
Velocity	720	°/s	max.
Mechanical Properties			
Load capacity / axial force	0.3	N	max.
Holding torque	0.005	Nm	max.
Torque cw / ccw (θ_z)	0.005	Nm	max.
Drive Properties			
Motor Type	PILine® ultrasonic piezomotor, performance class 1		
Reference point switch	Optical		
Miscellaneous			
Operating temperature range	0 to 40	°C	
Material	Al (black anodized)		
Mass	120	g	$\pm 5\%$
Cable length	1.5	m	$\pm 10\text{ mm}$
Connector	Sub-D connector, 15-pin (m)		
Recommended controller/driver	C-877.1U11: 1 channel, affordable compact device C-877.2U12: 2 channels, affordable bench-top C-867.1U: 1 channel C-867.2U: 2 channels		

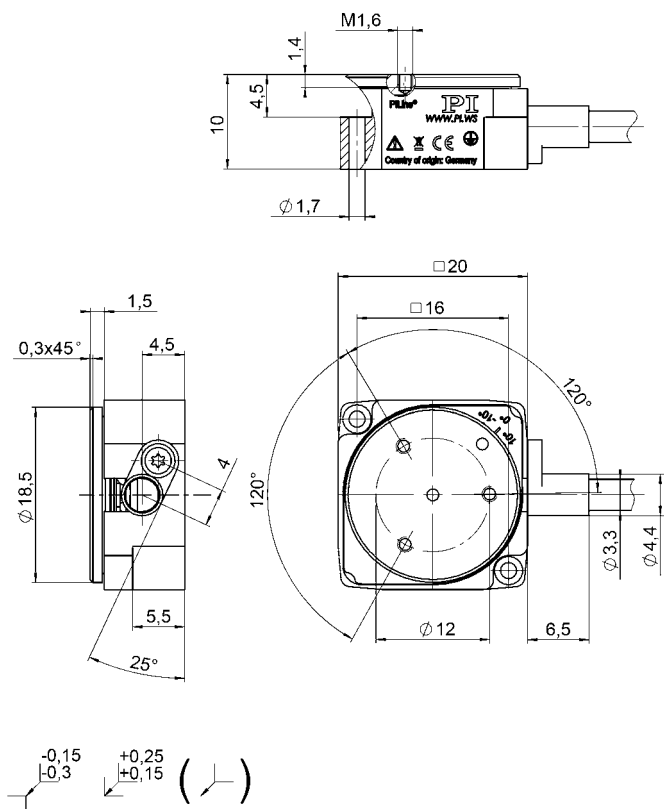

U-622, dimensions in mm

Fast Miniature Rotation Stage

WITH ULTRASONIC PIEZOMOTOR



U-624

- Only 30 mm edge length, height 12 mm
- Integrated, direct-measuring incremental encoder
- Rotation range >360°
- High velocity 720 °/s
- Drive torque 10 mNm

Small, precision-class rotation stage

Integrated, direct-measuring incremental encoder.
Rotation range >360°. Optical reference point switch

PILine® ultrasonic piezo motor

The piezoceramic ring-shaped motor acts directly on the rotating platform. Self-locking at rest, therefore no heat

generation. No drive noises. High velocity to 720 °/s.
Holding torque 10 mNm

Fields of application

Sample handling and positioning in research and industry for installations limited in space. Vacuum version for 10⁻⁶ hPa optional

Preliminary Data	U-624.03	Unit	Tolerance
Active axes	θ_z		
Motion and Positioning			
Rotation range	>360	°	
Integrated sensor	Incremental encoder		
Design resolution	35	μrad	
Min. incremental motion	105	μrad	typ.
Bidirectional repeatability	± 210	μrad	
Velocity	720	°/s	max.
Mechanical Properties			
Load capacity / axial force	1	N	max.
Holding torque	0.01	Nm	max.
Torque cw / ccw (θ_z)	0.01	Nm	max.
Drive Properties			
Motor Type	PILine® ultrasonic piezomotor, performance class 1		
Reference point switch	Optical		
Miscellaneous			
Operating temperature range	0 to 40	°C	
Material	Al (black anodized)		
Mass	130	g	$\pm 5\%$
Cable length	1.5	m	$\pm 10\text{ mm}$
Connector	Sub-D connector, 15-pin (m)		
Recommended controller/driver	C-877.1U11: 1 channel, affordable compact device C-877.2U12: 2 channels, affordable bench-top C-867.1U: 1 channel C-867.2U: 2 channels		

Ask about custom designs!

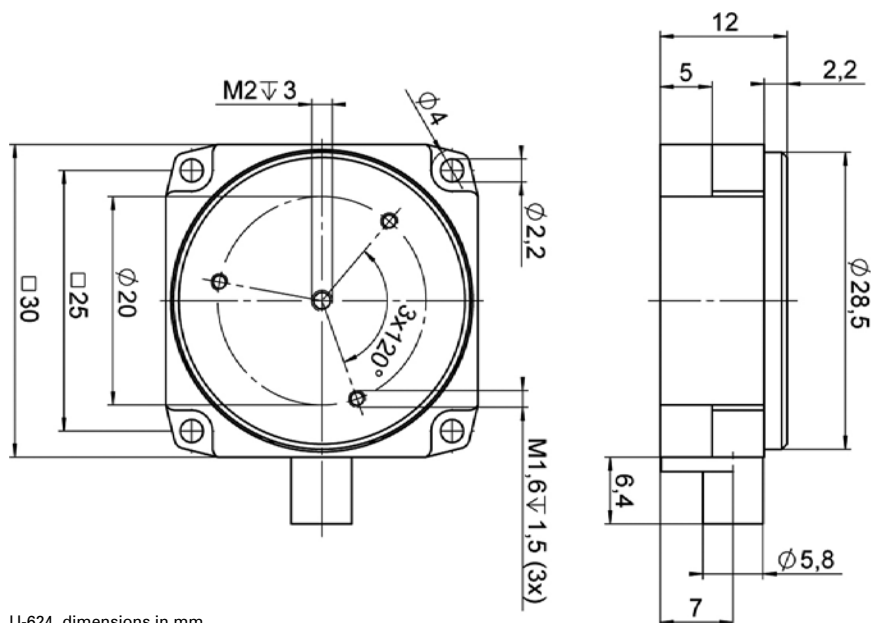

U-624, dimensions in mm

Fast Rotation Stage with Small Footprint

WITH ULTRASONIC PIEZOMOTOR



U-628

- Edge length 50 mm, height 19 mm
- Integrated, direct-measuring incremental encoder
- Rotation range $>360^\circ$
- High velocity 720 °/s
- Drive torque to 25 mNm, center load to 5 N
- Clear aperture

Precision-class rotation stage

Integrated optical encoder for direct metrology. Rotation range $>360^\circ$. Optical reference point switch. Central clear aperture with 7 mm diameter

PILine® ultrasonic piezo motor

Oscillating piezoceramic actuators act directly on the

ring-shaped runner. Self-locking at rest, thus no heat generation. High velocity to 720 °/s. Holding torque 25 mNm

Fields of application

Sample handling and positioning in research and industry for installations limited in space. Vacuum version for 10^{-6} hPa optional

	U-628.03	Unit	Tolerance
Active axes	θ_z		
Motion and Positioning			
Rotation range	>360	°	
Integrated sensor	Incremental encoder		
Design resolution	17	μrad	
Min. incremental motion	51	μrad	typ.
Bidirectional repeatability	± 102	μrad	
Velocity	720	°/s	max.
Mechanical Properties			
Load capacity / axial force	5	N	max.
Holding torque	0.03	Nm	max.
Torque cw / ccw (θ_z)	0.025	Nm	max.
Drive Properties			
Motor Type	PILine® ultrasonic piezomotor, performance class 1		
Reference point switch	Optical		
Miscellaneous			
Operating temperature range	0 to 40	°C	
Material	Al (black anodized)		
Mass	300	g	$\pm 5\%$
Cable length	1.5	m	$\pm 10\text{ mm}$
Connector	Sub-D connector, 15-pin (m)		
Recommended controller/driver	C-877.1U11: 1 channel, affordable compact device C-867.1U: 1 channel C-867.2U: 2 channels, C-877.2U12: 2 channels, affordable bench-top		

Ask about custom designs!

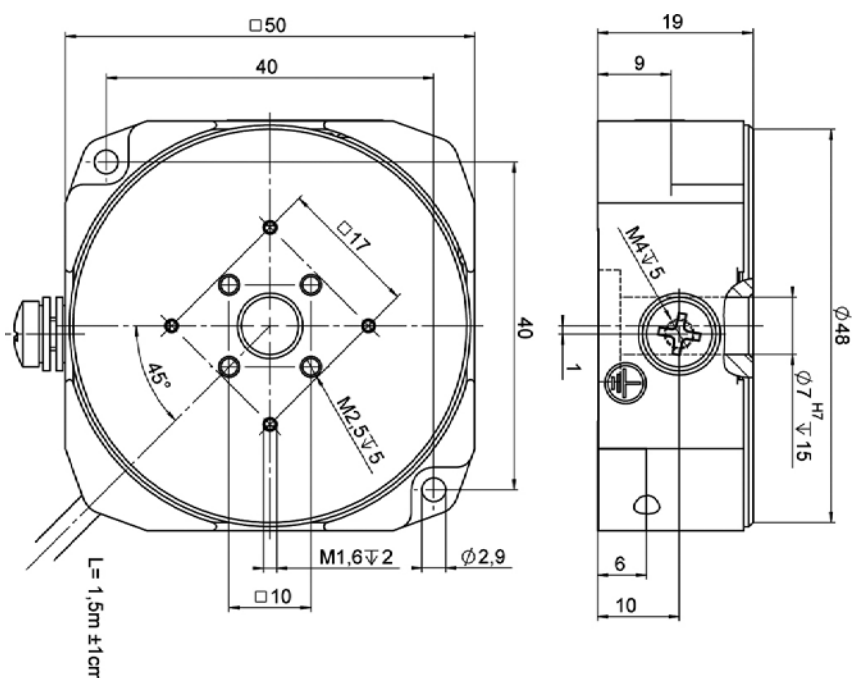

U-628, dimensions in mm

Rotation Stage with Low-Profile Design

FAST PILINE® DIRECT DRIVE

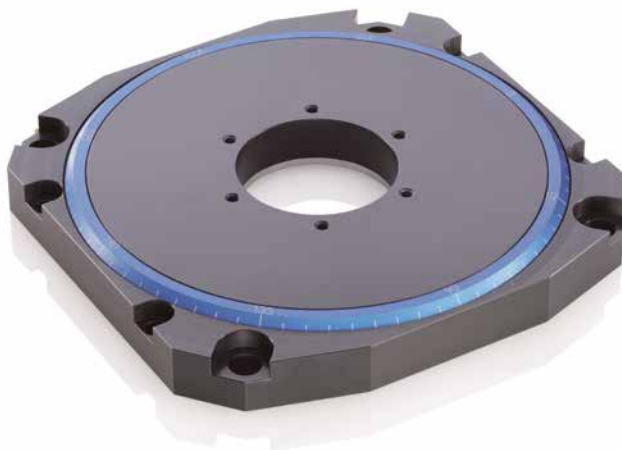

U-651

- Low profile: Only 14 mm height
- Integrated, direct-measuring incremental encoder with up to 4 μ rad resolution
- Rotation range $>360^\circ$
- High velocity of 720 $^\circ/s$
- Drive torque to 0.3 Nm in both directions of rotation
- Clear aperture with 36 mm diameter

Precision-class rotation stage

Integrated, direct-measuring incremental encoder.
Rotation range $>360^\circ$. Optical reference point switch.
High guiding accuracy due to crossed roller bearings.
Clear aperture center load capacity to 20 kg

PILine® ultrasonic piezo motor

Oscillating piezoceramic actuators act directly on the ring-shaped runner. Self-locking at rest, therefore no heat

generation. No drive noises. High velocity up to 720 $^\circ/s$.
Dynamic start / stop dynamics. Holding torque 0.3 Nm

Valid patents

US patent no. 6,765,335B2
European patent no. 1267425B1

Fields of application

Industry and research. For micromanipulation, automation, optical metrology

Preliminary Data	U-651.03	U-651.04	Unit	Tolerance
Active axes	θ_z	θ_z		
Motion and Positioning				
Rotation range	>360	>360	°	
Integrated sensor	Incremental encoder	Incremental encoder		
Design resolution	9	4	μrad	
Min. incremental motion	27	12	μrad	typ.
Bidirectional repeatability	± 54	± 24	μrad	
Velocity	720	720	°/s	max.
Mechanical Properties				
Load capacity / axial force	20	20	N	max.
Holding torque	0.3	0.3	Nm	max.
Torque cw / ccw (θ_z)	0.3	0.3	Nm	max.
Drive Properties				
Motor Type	PILine® ultrasonic piezomotor, performance class 2	PILine® ultrasonic piezomotor, performance class 2		
Reference point switch	Optical	Optical		
Miscellaneous				
Operating temperature range	0 to 40	0 to 40	°C	
Material	Al (black anodized)	Al (black anodized)		
Mass	500	500	g	$\pm 5\%$
Cable length	1.5	1.5	m	$\pm 10\text{ mm}$
Connector	Sub-D connector, 15-pin (m)	Sub-D connector, 15-pin (m)		
Recommended controller/driver	C-867.1U: 1 channel C-867.2U: 2 channels C-877.2U12: 2 channels, affordable bench-top	C-867.1U: 1 channel C-867.2U: 2 channels, C-877.2U12: 2 channels, affordable bench-top		

Ask about custom designs!
The U-651 stage series replace the M-660 series

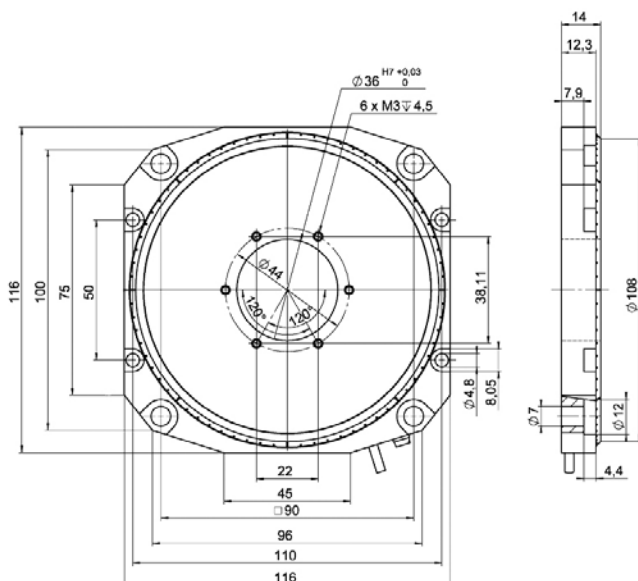

U-651, dimensions in mm

PILine® Motion Controller

FOR ULTRASONIC PIEZOMOTORS, 1 AND 2 AXES



C-867.U

- For PILINE® ultrasonic piezo linear motors
- 50 MHz encoder inputs for simultaneous high velocity and resolution
- USB, RS-232, SPI and analog interfaces (e.g., for a joystick)
- ID chip support

Servocontroller and power amplifier

One and two channels, bench-top, special PID controller for ultrasonic piezomotors. Network capable with up to 16 units on a single interface. Power amplifier for PILINE® ultrasonic piezomotors and stages with performance class 1, 2, and 3 piezomotors. Dynamic frequency control for optimum operation

Encoder inputs

Differential signal transmission for digital (A/B) or analog (sin/cos) encoder signals. BiSS interface support for absolute encoders. TTL signal inputs for limit and reference point switches

Digital communication

USB, RS-232, SPI and analog interfaces (e.g., for a joystick). Data recorder. Powerful macro programming language, e.g., for stand-alone operation. ID chip for quick startup, parameter changes on-the-fly. Extensive software support, e.g., LabVIEW, shared libraries for Windows and Linux



The two-channel C-867 controller serves to control XY scanning stages, as in this case a customized M-686 stage for microscopy

	C-867.1U	C-867.2U
	Controller for single-axis positioning or scanning stages	Controller for XY positioning or scanning stages
Drive types	PILine® Performance class 2 motors	PILine® Performance class 2 motors
Channels	1	2
Motion and control		
Servo characteristics	Programmable PID filters, parameter changes on the fly	Programmable PID filters, parameter changes on the fly
Trajectory profile modes	Trapezoidal	Trapezoidal
Encoder input	Sin/cos, A/B, differential, 50 MHz, BiSS interface	Sin/cos, A/B, differential, 50 MHz, BiSS interface
Stall detection	Servo off, triggered by programmable position error or power level	Servo off, triggered by programmable position error or power level
Limit switches	2 programmable TTL lines per channel	2 programmable TTL lines per channel
Reference point switch	1 programmable line per channel (active high / low)	1 programmable line per channel (active high / low)
Electrical properties		
Max. output power per channel	15 W	15 W
Max. output voltage per channel	200 V _{pp}	200 V _{pp}
Interface and operation		
Interface / communication	USB; RS-232, SPI	USB; RS-232, SPI
Motor connector	Sub-D 15-pin (f)	2 × Sub-D pin (f)
Controller network	Up to 16 units on a single interface	Up to 16 units on a single interface
I/O ports	4 analog / digital inputs 4 digital outputs to mini DIN 9 pin Digital: TTL Analog: 0 to 5 V	4 analog / digital inputs 4 digital outputs to mini DIN 9 pin Digital: TTL Analog: 0 to 5 V
Command set	PI General Command Set (GCS)	PI General Command Set (GCS)
User software	PIMikroMove	PIMikroMove
Software drivers	GCS-DLL (with code examples for the most common programming languages such as C++, C#, VB.NET, Python, Delphi), LabVIEW driver, MATLAB library	GCS-DLL (with code examples for the most common programming languages such as C++, C#, VB.NET, Python, Delphi), LabVIEW driver, MATLAB library
Supported functionality	Startup macro, macro, data recorder for recording operating data such as motor voltage, velocity, position or position error	Startup macro, macro, data recorder for recording operating data such as motor voltage, velocity, position or position error
Manual control	Pushbutton box, joystick (for 2 axes), Y-cable for 2-D motion	Pushbutton box, joystick (for 2 axes)
Miscellaneous		
Operating voltage	24 VDC from external power supply (included)	24 VDC from external power supply (included)
Max. operating current	300 mA plus motor current (max. 2 A)	600 mA plus motor current (max. 4 A)
Operating temperature range	5 to 40 °C	5 to 40 °C
Mass	1 kg	2.4 kg
Dimensions	206 mm × 130 mm × 66 mm (incl. mounting rails)	320 mm × 150 mm × 80.5 mm (incl. mounting rails)

Ask about custom designs!

PILine® Motion Controller

FOR ULTRASONIC PIEZOMOTORS, COST-EFFICIENT AND COMPACT



C-877

- Integrated power amplifier with dynamic frequency control
- PID servo control with dynamic parameter switching
- Data recorder
- Powerful macro programming language, e.g., for stand-alone operation
- Extensive software support, e.g., for LabVIEW, shared libraries for Windows and Linux

Servocontroller and power amplifier

One and two channels, bench-top, special PID controller for ultrasonic piezomotors. Integrated power amplifier for PLine® drives and stages in performance classes 1 and 2 (C-877.1U11, only class 1). Dynamic frequency control for optimum control

Incremental encoders

Differential signal transmission (A/B). TTL signal inputs for limit and reference point switches

Digital communication

USB and RS-232 interfaces (e.g., for a joystick). Data recorder. Powerful macro programming language, e.g., for stand-alone operation. Extensive software support, e.g., LabVIEW, dynamic libraries for Windows and Linux



	C-877.1U11	C-877.2U12
Function	Controller for single-axis positioning or scanning stages with PILine® ultrasonic piezomotors (performance class 1)	Controller for single-axis positioning and scanning stages with PILine® ultrasonic piezomotors (performance class 1 and 2)
Channels	1	2
Motion and control		
Servo characteristics	PID controller, parameter change on-the-fly	PID controller, parameter change on-the-fly
Servo cycle time	100 µs	100 µs
Profile generator	Trapezoidal velocity profile	Trapezoidal velocity profile
Encoder input	A/B quadrature TTL level, differential according to RS-422	A/B quadrature TTL level, differential according to RS-422
Stall detection	Servo off, triggered by programmable position error	Servo off, triggered by programmable position error
Limit switches	2 × TTL (polarity programmable)	2 × TTL (polarity programmable)
Reference point switch	1 × TTL	1 × TTL
Electrical properties		
Max. output power per channel	15 W	24 W
Max. output voltage per channel	200 V _{pp} , 71 V _{eff}	200 V _{pp} , 71 V _{eff}
Interface and operation		
Interface / communication	USB	USB; RS-232
Motor connector	Sub-D 15-pin (f)	2 × Sub-D 15-pin (f)
Command set	PI General Command Set (GCS)	PI General Command Set (GCS)
User software	PIMikroMove	PIMikroMove
Software drivers	LabVIEW drivers, dynamic libraries for Windows and Linux	LabVIEW drivers, dynamic libraries for Windows and Linux
Supported functionality	Point-to-point motion, startup macro, data recorder for recording parameters such as motor voltage, velocity, position or position errors; internal safety circuitry: Watchdog timer; ID chip	Point-to-point motion, startup macro, data recorder for recording parameters such as motor voltage, velocity, position or position errors; internal safety circuitry: Watchdog timer; ID chip
Manual control	–	–
Miscellaneous		
Operating voltage	24 VDC from external power supply (included)	24 VDC from external power supply (included)
Max. operating current	300 mA plus motor current (max. 0.8 A)	600 mA plus motor current (max. 4 A)
Operating temperature range	5 to 40 °C	5 to 40 °C
Mass	0.13 kg	2.4 kg
Dimensions	95 mm × 71 mm × 24 mm (incl. mounting rails)	320 mm × 150 mm × 80.5 mm (incl. mounting rails)

Ask about custom designs!

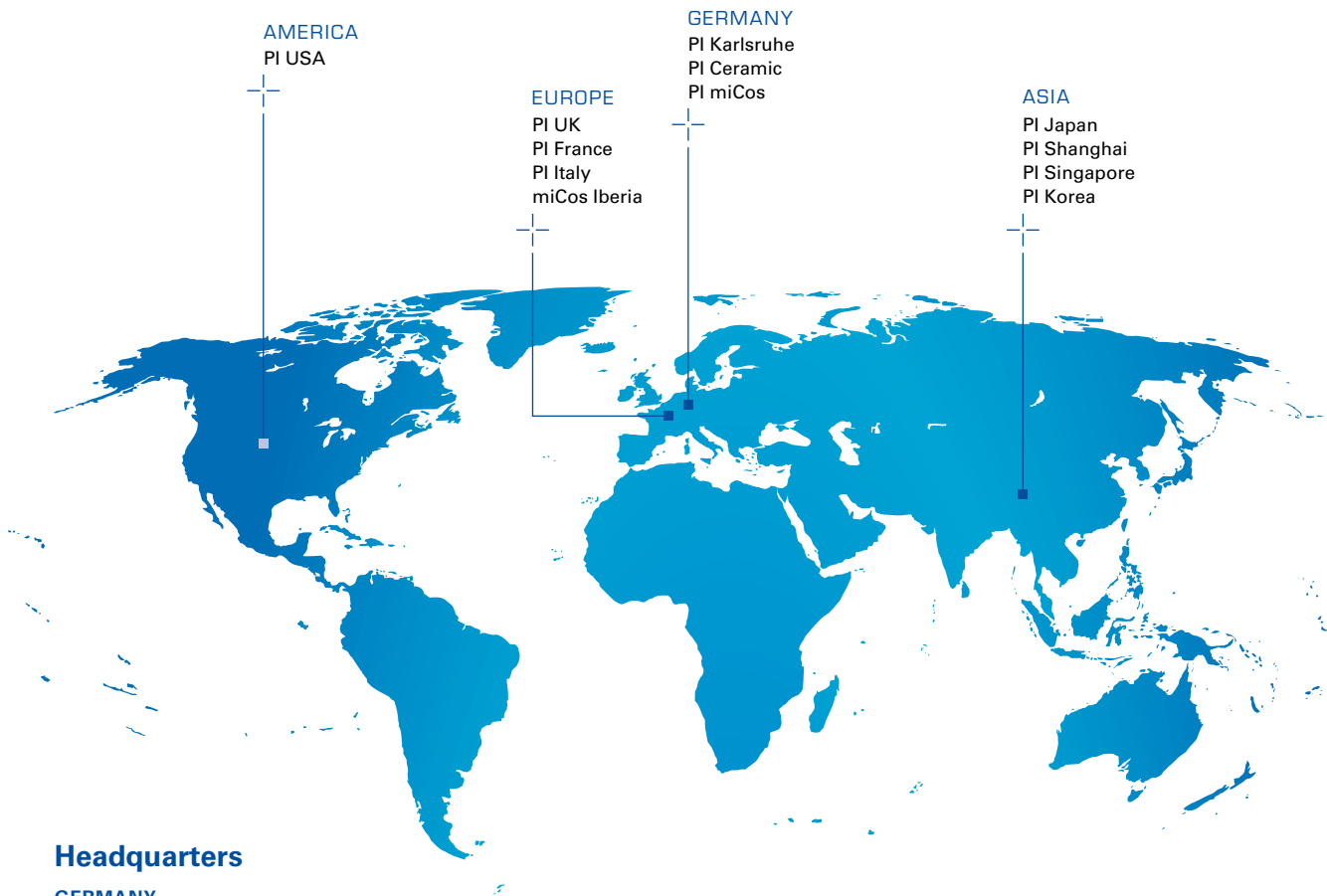

Headquarters

GERMANY

Physik Instrumente (PI) GmbH & Co. KG
 Auf der Roemerstr. 1
 76228 Karlsruhe
 Phone +49 721 4846-0
 Fax +49 721 4846-1019
 info@pi.ws
 www.pi.ws

PI miCos GmbH
 Eschbach
 info@pimicos.com
 www.pi.ws

PI Ceramic GmbH
 Lederhose
 info@piceramic.com
 www.piceramic.com



Subsidiaries

USA (East) & CANADA

PI (Physik Instrumente) L.P.
 Auburn, MA 01501
 info@pi-usa.us
 www.pi-usa.us

USA (West) & MEXICO

PI (Physik Instrumente) L.P.
 Irvine, CA 92620
 info@pi-usa.us
 www.pi-usa.us

UK & IRELAND

PI (Physik Instrumente) Ltd.
 Cranfield, Bedford
 uk@pi.ws
 www.physikinstrumente.co.uk

ITALY

Physik Instrumente (PI) S. r. l.
 Bresso
 info@pionline.it
 www.pionline.it

JAPAN

PI Japan Co., Ltd.
 Tokyo
 info@pi-japan.jp
 www.pi-japan.jp

PI Japan Co., Ltd.
 Osaka
 info@pi-japan.jp
 www.pi-japan.jp

SOUTHEAST ASIA

PI (Physik Instrumente) Singapore LLP
 Singapore
 info-sg@pi.ws
 www.pi-singapore.sg
 For ID / MY / PH / SG / TH / VNM / TW

KOREA

PI Korea Ltd.
 Seoul
 info-kr@pi.ws
 www.pikorea.co.kr

FRANCE

PI France S.A.S.
 Montrouge
 info.france@pi.ws
 www.pi.ws

SPAIN

Micos Iberia S.L.
 Vilanova i la Geltrú
 info@pimicos.es
 www.pimicos.es

CHINA

Physik Instrumente (PI Shanghai) Co., Ltd.
 Shanghai
 info@pi-china.cn
 www.pi-china.cn

Physik Instrumente (PI Shanghai) Co., Ltd.
 Peking
 info@pi-china.cn
 www.pi-china.cn