

REACTIONLESS, MOMENTUM COMPENSATED RESONANT LINEAR DRIVE

S. Kovalev, R. Glöß
Physik Instrumente (PI) GmbH & Co., Waldbronn, Germany

Abstract:

A new precision reactionless linear drive has been developed using the principle of the mechanical resonance. This allows to significantly reduce the power consumption and the weight of the whole system. To reduce the reaction forces on the drive base an active reaction compensation has been implemented. The presented drive has a 26 mm or 1 inch range of motion and achieves a position resolution of better 1 μm at a maximum speed of 1,7 m/sec with 20 cycles per second. We describe the principle of the momentum compensation and the force generation as follows. The paper closes with the introduction of the control concept.

Introduction

Through the application of direct drives a significant advance in the field of precision drive technology has been achieved during the past years [1]. Improved dynamic properties of such systems is a result of the increased drive forces. The reaction of this forces subjected to the base remains, however, a problem, particularly for precision applications. The vibrations resulting from the reaction forces increase the power losses and reduce the dynamic properties of the drive. Passive damping of the vibration requires a rigid base plate, which can be tenfold up to fiftyfold of the drive weight [2]. Active compensation of the reaction forces do not possess these disadvantages and allow to reduce substantially the weight of the whole system.

Further, to significantly decrease the power losses in the drive, a resonant moving principle can be used for the special applications with the constant duty cycle frequency.

Design

Figure 1 gives an overview over the whole system and Figure 2 shows the structure of the drive itself.

The stage (2) is connected with two linked up springs (11) through the transmission rod (14). The stiffness of the springs and the moving mass determine the resonant frequency and build the first, "drive" part of the whole system. The compensating mass (7) builds with two linked up springs (8) the second, "compensating" part of the drive with the same resonant frequency. The springs of the both resonant systems are linked up consecutively in the housing (4) which is fixed on the drive case (not shown in this figure).

The drive and the compensation forces are produced by two so-called voice-coil actuators (13) and (10). The moving ring coils (12) and (9) exert the driven forces on the spring-mass systems through the actuating rods (3) and (5). The moving stage and the compensating mass are mechanically guided with the

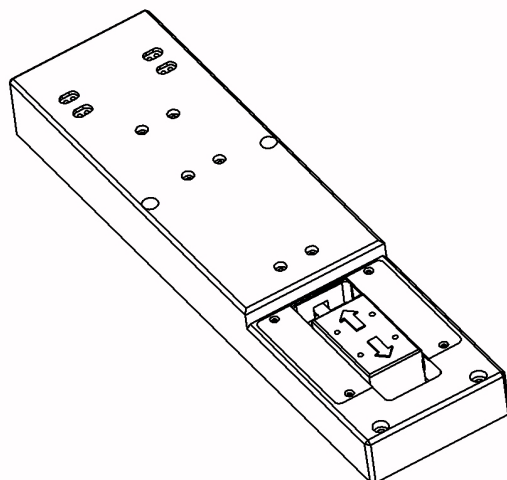

Fig. 1: CAD - view of the linear drive.

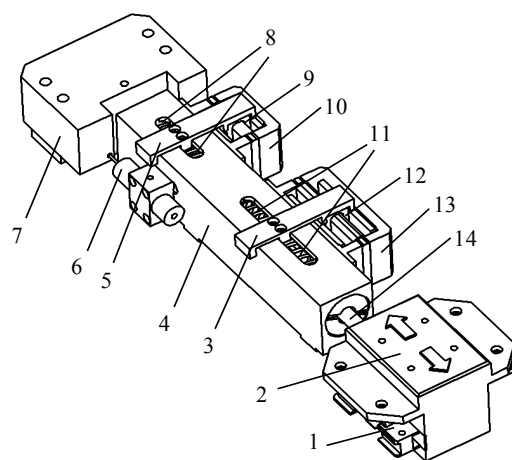

Fig. 2: CAD-view of the drive structure

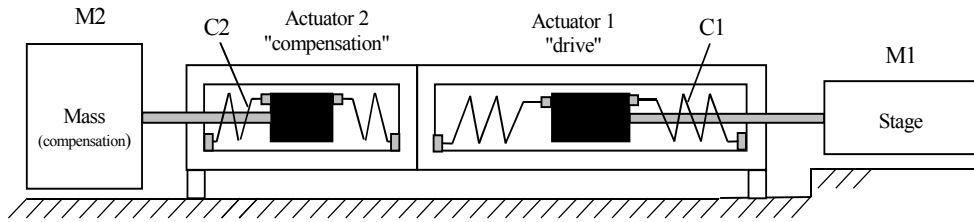

Fig. 3: Principle drawing of the drive

miniature precise ball slides (not shown). The stage further carries a grid for the incremental linear measurement system (1) which is mounted on the drive base. The measurement system precisely determines the position of the stage. The spring housing carries another linear analogue sensor (6) that determines the position of the compensating mass.

Force generation and reaction compensation

Figure 3 shows the model of the drive. The drive combines two linear direct drive actuators with a mechanical guidance elements. The direct drive elements utilise the electrodynamic force generation principle with moving coils. This allows a reduction of the eddy-current forces and avoids thus power losses on the high duty cycle frequencies. Additionally the moved coils do not possess attractive forces to the stator. The moving masses build with the linked up springs two resonance systems, which should be placed on one line. Further, the centres of gravity for both masses are situated on the same line. This can reduce the mechanical moments and allows better reaction compensation. The forces on the moving masses and therefore the reactions on the stage can be determined easily by the mechanical output variable x and the constant factors of the resonant circuit, with the moving mass m , damping factor b and spring stiffness c .

$$F = -m \cdot \ddot{x}(t) = b \cdot \dot{x}(t) + c \cdot x(t) \quad (1)$$

Both resonant systems should be excite with the same eigen frequency ω_0 , however, with the phase difference φ_0 between them. The positions x and X of the drive and compensation actuators can be represented with the cosine-waves.

$$\begin{aligned} x(t) &= x_0 \cdot \cos(\omega_0 t) \\ X(t) &= X_0 \cdot \cos(\omega_0 t + \varphi_0) \end{aligned} \quad (2)$$

The minimum of the reaction forces in the whole drive can be achieved if the sum of both reaction forces is the smallest.

$$\begin{aligned} F_{drive} + F_{comp} &\rightarrow \min, \text{ with} \\ F_{drive} &= M_1 \cdot x_0 \cdot \omega_0^2 \cos(\omega_0 t) = \\ &= -b_1 \cdot x_0 \cdot \omega_0 \sin(\omega_0 t) + c_1 \cdot x_0 \cos(\omega_0 t), \text{ and} \\ F_{comp} &= M_2 \cdot X_0 \cdot \omega_0^2 \cos(\omega_0 t + \varphi_0) = \\ &= -b_2 \cdot X_0 \cdot \omega_0 \sin(\omega_0 t + \varphi_0) + c_2 \cdot X_0 \cos(\omega_0 t + \varphi_0) \end{aligned} \quad (3)$$

The smallest reaction forces could be achieved only if the compensation mass moves in the opposite phase with the drive stage. This 180-degree phase shift inverts all parts of the equation for the compensation system. All similar parts of the equation (3) should have the same value to achieve nearly full reaction compensation. This is enough to describe the most important design parameters of the drive.

$$\begin{aligned} \varphi_0 &= \pi \\ \frac{x_0}{X_0} &= \frac{M_2}{M_1} = \frac{c_2}{c_1} = \frac{b_2}{b_1} \end{aligned} \quad (4)$$

The equation (4) shows that with larger compensation mass the smaller moving amplitude of the compensate mass could be achieved. This feature is very useful to reduce the drive dimensions. The same fraction for both spring stiffness c_1 and c_2 means the requirement on the equal eigen frequencies of the resonant systems. Actually there is no simple method to mechanically design the damping factors b_1 and b_2 in accordance with the equation (4). It is very important therefore to achieve the smallest damping factors. There is no need to design such common powerful voice coil actuators that can statically move the stages over the whole displacement range. The driving forces should compensate the power losses due to the damping in the resonant systems. Another requirement on the actuator force can be set by the maximum starting time.

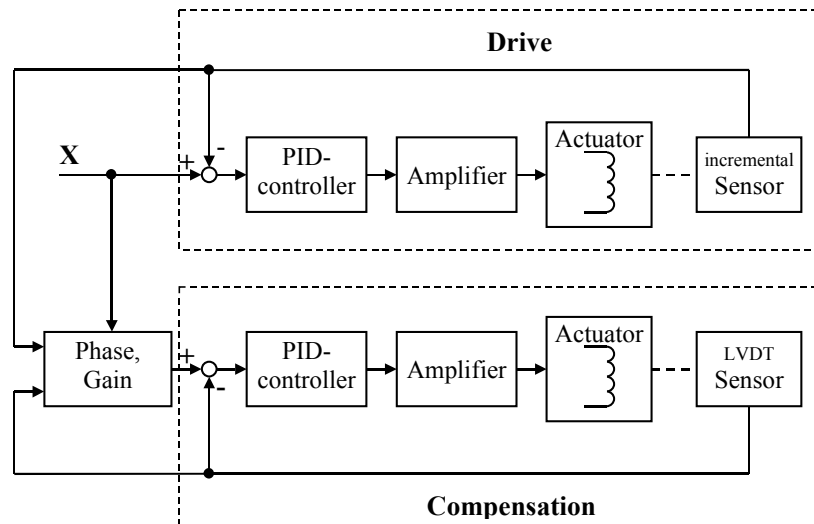

Fig. 4: Structure of the control system hardware

Control

Above all, the control of such system requires a fast hardware. Figure 4 shows the hardware structure of the control system based on two analogue PID-controllers.

An incremental linear measurement system with hardware interpolation allows to determine the drive position x with a resolution of better $1 \mu\text{m}$ and has a bandwidth of 4 MHz. There is no possibility to control the position of such mechanical system on this frequency. Therefore only amplitude control on the resonant frequency has been realised.

The second "compensation" actuator will be excited with the same frequency. The phase shift and the gain of this excitation frequency will be set through the special part of the control system so, that the reaction forces on the base remain small on all possible amplitudes of the drive.

An analogue linear variable differential transformer (LVDT) sensor allows to close the control loop of the compensation resonant system.

Some numerical simulations of such control algorithms have been done to determine the expected parameters of the drive. The moving mass of 0,15 kg with the compensation mass of 0,6 kg and the base plate of 2 kg was simulated. The reaction compensation during the start of the drive is shown in figure 5. After the starting time only the sine-wave force of about 0,3 N amplitude will remain. In comparison to the reaction force of about 30 N of the single resonant system in figure 6, only one percent of this force will remain. The simulated vibrations on the drive base are shown in figure 7. After a period of time a vibration of about $0,5 \mu\text{m}$ amplitude will remain.

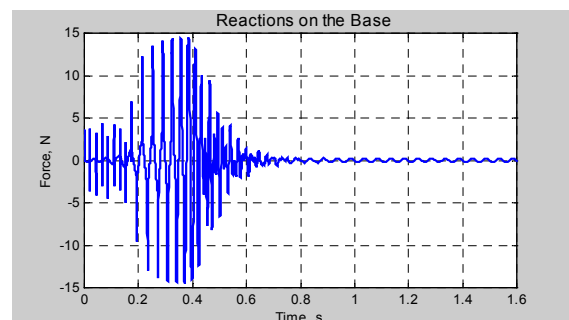

Fig. 5: Reactions on the base when started

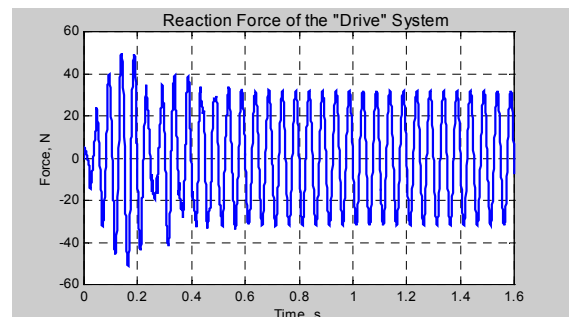

Fig. 6: Reaction force of the "drive" system

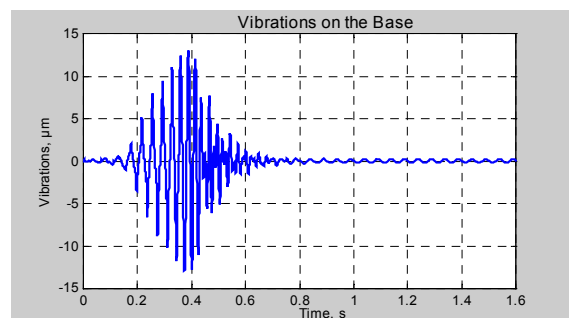

Fig. 7: Simulation of the vibration when started

Some experimental results

The results of the very accurate measurement with a laser vibrometer are shown in figures 8 to 11. In figure 8 the overview of the drive and the vibration amplitude with 20 Hz frequency is shown. This measurement allows to observe the effects on the drive base caused by the non-compensated torsion moments and forces. The mechanical vibration amplitude achieves a value of much less than 1 μm on the maximum drive amplitude of $\pm 13 \text{ mm}$. The deformations of the base plate during this vibration are shown as a 3-dimensional plot in figure 9.

The quality of the reaction compensation can be determined through the position deviation of the base during the drive duty cycle. After a period of

remaining forces on the drive base result from the difference in the damping factors and frictional forces for both resonant systems. The value of these forces is less than 5 % of the drive forces.

Conclusion

The presented drive with an active reaction compensation allows to reduce the vibrations on the driving case to better 95 % without increasing the base plate weight. The resonant working principle helps to achieve the high duty cycle frequency of 20 Hz and the range of motion of 26 mm with a resolution of better 1 μm without substantial power losses.

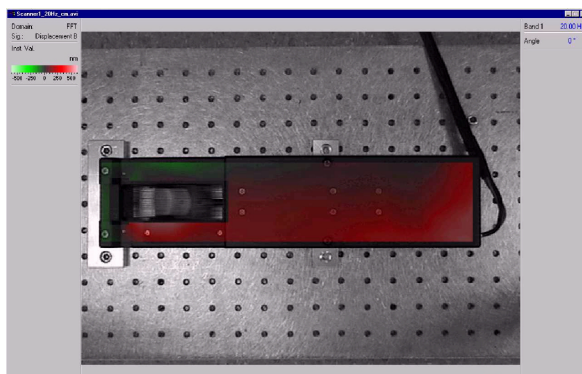

Fig. 8: Vibration measurements on the base.

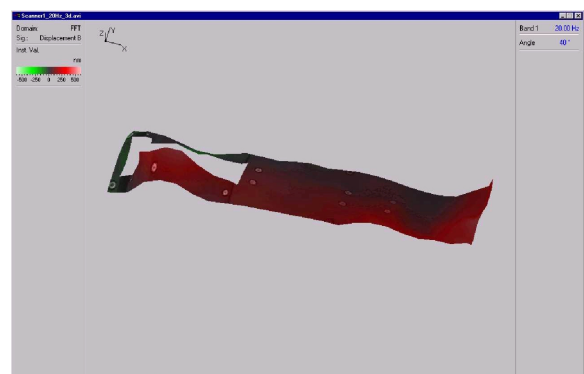

Fig. 9: Vibration of the base with 20 Hz

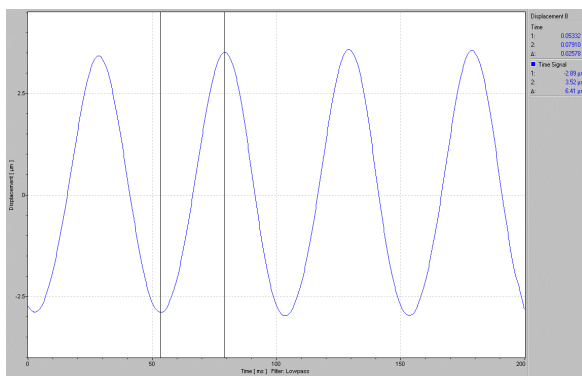

Fig. 10: Vibration amplitude on the base

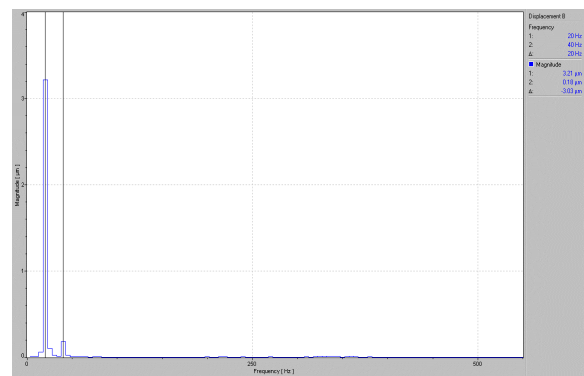

Fig. 11: Spectrum analysis of the vibrations

time, that is used to stabilize the drive movement, remains the sine-wave vibration with an amplitude of about 2,5 μm . The spectrum analysis of this vibration in figure 11 shows that the higher harmonics would not be excited. The second harmonic with a frequency of 40 Hz has an amplitude of only 0,2 μm .

This experiment shows the expected good quality of the momentum and reaction compensation. The

References

- [1] Kallenbach, E.; Bögelsack, G.: Gerätetechnische Antriebe. Hanser Verlag München 1991
- [2] Krause, W.: Konstruktionselemente der Feinmechanik. Carl Hanser Verlag 1993